

TECHNICAL MANUAL

**UNIT AND DIRECT SUPPORT (DS)
MAINTENANCE MANUAL(INCLUDING REPAIR
PARTS AND SPECIAL TOOLS LIST)**

FOR

**10,000 LB. EXTERNAL TRANSPORT
SLING ASSEMBLY**

(NSN 1670-01-027-2902)

**25,000 LB. EXTERNAL TRANSPORT
SLING ASSEMBLY**

(NSN 1670-01-027-2900)

**5,000 LB. EXTERNAL TRANSPORT
CARGO NET**

(NSN 1670-01-058-3811)

**10,000 LB. EXTERNAL TRANSPORT
CARGO NET**

(NSN 1670-01-058-3810)

Approved for public release; distribution is unlimited.

HEADQUARTERS, DEPARTMENT OF THE ARMY

22 May 1991

WARNING

DEATH could result if Inspections are not performed as specified in this manual. Perform all Inspections as specified.

DEATH from burns or equipment failure could result if cleaning solvents other than tetrachloroethylene are used in cleaning this equipment. Other solvents shall not be used because of their flammable properties and nylon-damaging substances.

Prolonged inhalation of tetrachloroethylene vapors can cause respiratory injury. Provide adequate ventilation when using it. Also avoid skin contact. Repeated exposure can cause injury.

Exercise extreme care when using petroleum products to destroy equipment by fire, as severe burns or DEATH could result.

FIRST AID

For First Aid treatment, refer to FM 21-11

a/(b blank)

TECHNICAL MANUAL
 No. 10-1670-295-23&P

HEADQUARTERS
 DEPARTMENT OF THE ARMY
 Washington, DC, 22 May 1991

**Unit and Intermediate Direct Support (DS) Maintenance Manual
 (Including Repair Parts and Special Tools List)
 for
 10,000 AND 25,000 LB. EXTERNAL TRANSPORT SLING ASSEMBLY
 (NSN 1670-01-027-2902 AND NSN 1670-01-027-2900)
 AND
 5,000 AND 10,000 LB. EXTERNAL TRANSPORT CARGO NET
 (NSN 1670-01-058-3811 AND NSN 1670-01-058-3810)**

Current as of 3 August 1990

REPORTING ERRORS AND RECOMMENDING IMPROVEMENTS

You can help improve this manual. If you find any mistakes or if you know of a way to improve the procedures, please let us know. Mail your letter, DA Form 2028 (Recommended Changes to Publications and Blank Forms), or DA Form 2028-2, located in the back of this manual direct to Commander, U S Army Troop Support Command, ATTN: AMSTR-MCTS, 4300 Goodfellow Blvd., St. Louis, MO 63120-1798. A reply will be furnished directly to you.

Approved for public release, distribution is unlimited.

TABLE OF CONTENTS

	Page
CHAPTER 1	INTRODUCTION 1-1
	OVERVIEW 1-1
Section I	General..... 1-1
Section II	Equipment Description and Data..... 1-3
Section III	Principles of Operation..... 1-6
CHAPTER 2	UNIT AND INTERMEDIATE DIRECT SUPPORT (DS) MAINTENANCE FUNCTIONS..... 2-1
Section I	Repair Parts, Special Tools, Test, Measurement and Diagnostic Equipment (TMDE) and Support Equipment..... 2-1
Section II	Service Upon Receipt 2-2
Section III	Unit Preventive Maintenance Checks and Services (PMCS). 2-2
Section IV	Unit and Intermediate Direct Support (DS) Maintenance Procedures..... 2-5
Section V	External Transport Sling Assembly Repair 2-11
Section VI	External Transport Cargo Net Repair 2-28
Section VII	Preparation for Storage or Shipment..... 2-46
APPENDIX A	REFERENCES A-1
APPENDIX B	MAINTENANCE ALLOCATION CHART..... B-1

TABLE OF CONTENTS (cont)

	Page	Illust/ Figure
APPENDIX C REPAIR PARTS AND SPECIAL TOOLS LIST.....	C-1	
Section I. Introduction.....	C-1	
Section II. Repair Parts List		
Group 00 Sling Assembly.....	C-11	C-1
Group 01 Apex Fitting	C-13	C-2
Group 02 Sling Leg	C-11	C-1
Group 03 Grabhook Assembly	C-15	C-3
Group 04 Chain.....	C-11	C-1
Group 05 Storage Bag	C-11	
Group 00 Cargo Net.....	C-17	C-4
Group 01 Apex Fitting	C-17	C-4
Group 02 Hook.....	C-17	C-4
Group 03 Lifting Leg.....	C-17	C-5
Group 04 Net	C-17	C-4
Group 05 Storage Bag	C-17	
Group 99 Bulk Materials.....	C-19	
Section III	Special Tools List (no listing required)...	C-19
Section IV Cross Reference Indexes.....	C-21	
APPENDIX D EXPENDABLE/DURABLE SUPPLIES AND MATERIALS LIST	D-1	
APPENDIX E ILLUSTRATED LIST OF MANUFACTURED ITEMS	E-1	E-1
INDEX	Index 1	

LIST OF ILLUSTRATIONS

Figure Number	Title	Page
1-1	10,000 and 25,000 lb. External Transport Sling, 5,000 and 10,000 lb.	
	External Transport Cargo Nets	1-0
1-2	10,000 and 25,000 lb. External Transport Sling Assembly	1-4
1-3	5,000 and 10,000 lb. External Transport Cargo Nets	1-4
2-1	Apex Spacer Replacement.....	2-13
2-2	Apex Pin Replacement.....	2-14
2-3	Bolt Replacement.....	2-15
2-4	Nut Replacement	2-16
2-5	Cotter Pin Replacement	2-17
2-6	Sling Leg Replacement	2-19
2-7	Grabhook Keeper Replacement	2-20
2-8	Grabhook Coupler Link Replacement.....	2-21
2-9	Keeper Replacement.....	2-22
2-10	Keeper Bolt Replacement.....	2-23
2-11	Grabhook Spacer Replacement.....	2-24
2-12	Snap Ring Replacement.....	2-25
2-13	Coupler Link Replacement	2-26
2-14	Chain Replacement.....	2-27
2-15	Apex Fitting Replacement	2-29
2-16	Hook Replacement.....	2-31
2-17	Splicing Lifting Leg.....	2-33
2-18	Lifting Leg Stitch Pattern	2-33
2-19	Replacing Lifting Legs.....	2-34
2-20	Lifting Leg Replacement Details.....	2-34
2-21	Buffer Replacement	2-35
2-22	Keeper Strap Replacement	2-37
2-23	Border Cord Repair Knot.....	2-39
2-24	Border Cord Repair Complete	2-39
2-25	Center Net Repair	2-40
2-26	Repair Cord #1	2-41
2-27	Repair Cord #2.....	2-42
2-28	Repair Cord #3.....	2-42
2-29	Repair Cord #1 in Place	2-43
2-30	Repair Cord #2 in Place	2-44
2-31	Net Repair Complete.....	2-45
2-31	Net Repair Complete.....	2-45

LIST OF TABLES

Table Number	Title	Page
1-1	Visible Differences Between the 10,000 and 25,000-Pound Capacity Sling Set..... ..	1-6
1-2	Visible Differences Between the 5,000 and 10,000-Pound Cargo Net Sets..... ..	1-6
2-1	Unit Preventive Maintenance Checks and Services (PMCS) for External Transport Sling Assemblies..... ..	2-4
2-2	Unit Preventive Maintenance Checks and Services (PMCS) for External Transport Cargo Nets..... ..	2-5

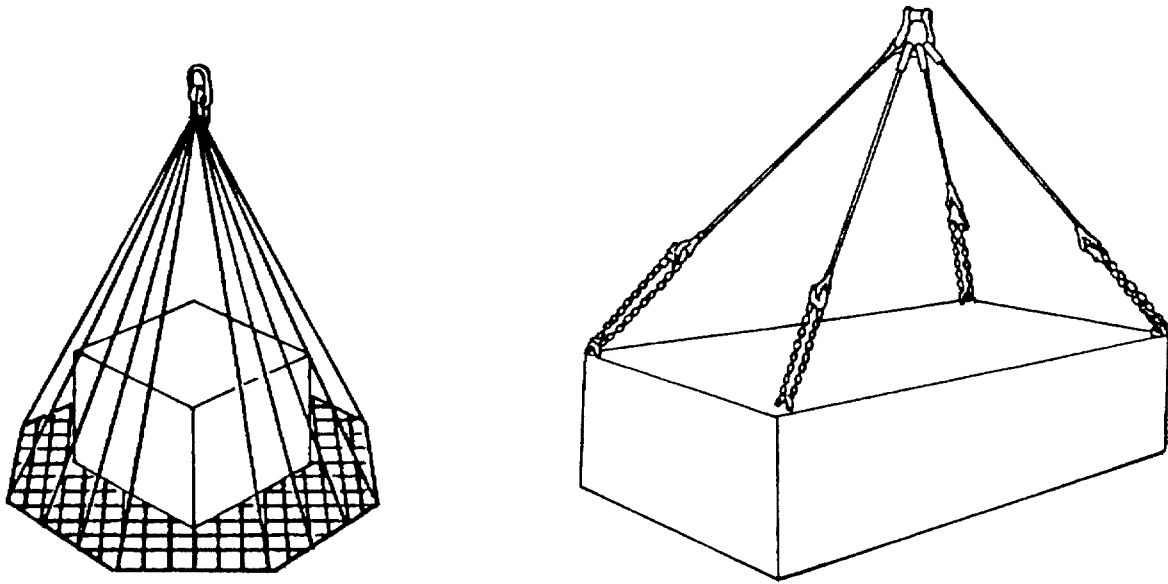

Figure 1-1. 10,000 lb. and 25,000 lb. External Transport Sling, 5,000 lb. , and 10,000 lb. External Transport Cargo Nets.

CHAPTER 1
INTRODUCTION

	Page
Section I. General.....	1-1
Section II. Equipment Description and Data	1-3

OVERVIEW

This chapter includes the general information common to all external transport slings and cargo nets including preparation for storage or shipment, equipment data, and equipment differences, etc.

SECTION I. GENERAL

Paragraph	Page
1-1 Scope.....	1-1
1-2 Maintenance Forms and Records	1-1
1-3 Destruction of Army Materiel to Prevent Enemy Use	1-1
1-4 Preparation for Storage or Shipment	1-2
1-5 Reporting of Equipment Improvement Recommendations (EIR).....	1-2

1-1. **Scope.** The scope of this manual is described in the following subparagraphs.

a. Type of Manual. This manual provides unit and intermediate direct support (DS) maintenance instructions” for the 10,000 and 25,000 lb. External Transport Slings Assemblies NSN 1670-01-027-2902 and NSN 1670-01-027-2900, and the 5,000 and 10,000 lb. External Transport Cargo Nets NSN 1670-01-058-3811 and NSN 1670-01-058-3810 (figure 1-1). This manual also includes a Repair Parts and Special Tools List located in Appendix C.

b. Equipment Name. 10,000 and 25,000 lb. External Transport Sling Assemblies hereinafter known as sling assemblies 5,000 and 10,000 lb. External Transport Cargo nets hereinafter known as cargo nets.

c. Purpose of Equipment. The purpose of the sling assemblies and the cargo nets is to externally transport cargo, ranging in weight from 5,000 to 25,000 lb. .

1-2. **Maintenance Forms and Records.** Department of the Army forms and procedures used for equipment maintenance will be those prescribed by DA PAM 738-750, The Army Maintenance Management System (TAMMS) and DA PAM 738-751, The Army Maintenance Management System-Aviation.

1-3. **Destruction of Army Materiel to Prevent Enemy Use.** Destruction methods are described in the following subparagraphs.

a. General.

(1) Objective. Methods of destruction used to inflict damage on external transport equipment make it impossible to restore equipment to a usable condition in a combat zone by either repair or cannibalization.

(2) *Authority.* Destruction of external transport equipment that is in imminent danger of capture by an enemy is a command decision that must be made by a battalion or higher commander or the equivalent

(3) *Implementation plan.* All units which possess external transport equipment should have a plan for the implementation of destruction procedures

(4) *Training.* All personnel who use external transport equipment should receive thorough training on external transport equipment destruction procedures and methods. The destruction methods demonstrated during training should be simulated. Upon completion of training, all applicable personnel should be thoroughly familiar with external transport equipment destruction methods and be capable of performing destruction without immediate reference to any publication.

(5) *Specific methods.* Specific methods of destroying Army material to prevent enemy use shall be by mechanical means, fire or by use of natural surroundings

b. *Destruction by Mechanical Means.* External transport equipment metal assemblies and parts shall be destroyed using hammers, bolt cutters, files, hacksaws, drills, screwdrivers, crowbars, or other similar devices to smash, break, bend or cut.

WARNING

Exercise extreme care when using petroleum products to destroy equipment by fire, as severe burns or death could result.

c. *Destruction By Fire.* Items that can be destroyed by fire shall be burned. The destruction of equipment by use of fire is an effective method of destroying low-melting-point metal items (e.g., sling legs and threaded portions of nuts and bolts. However, mechanical destruction should be completed first, whenever possible, before initiating destruction by fire. When items to be destroyed are made of metal, textile materials (or some comparable low combustible material) should be packed under and around the items, then soaked with a flammable petroleum product and ignited. Proper concentration of equipment which is suitable for burning will provide a hotter and more destructive fire.

d. *Destruction By Use of Natural Surroundings.* Small vital parts of assemblies which are easily accessible may be disposed of as follows. Disposal or denial of equipment to an enemy may be accomplished through use of natural surroundings. Accessible vital parts of assemblies may be removed and scattered through dense foliage, buried in dirt or sand, or thrown into a lake, stream, or other body of water. Total submersion of equipment in a body of water will provide water damage as well as concealment. Saltwater will inflict extensive damage to external transport equipment.

1-4. **Preparation for Storage or Shipment.** For storage, refer to Chapter 2, Section VII of this manual.

1-5. **Reporting of Equipment Improvement Recommendations (EIR).** If your sling assemblies or cargo nets need improvement, let us know Send us an EIR You, the user, are the only one who can tell us what you don't like about your equipment Let us know why you don't like the design or performance. Put in on as SF368 Quality Deficiency Report (QDR). Mail It to us at Commander, U.S. Army Troop Support Command, ATTN: AMSTR-QS, 4300 Goodfellow Blvd., St. Louis, MO 63120-1798. We will send you a reply

SECTION II. EQUIPMENT DESCRIPTION AND DATA

Paragraph		Page
1-6	Equipment Characteristics, Capabilities, and Features	1-3
1-7	Location and Description of Major Components.....	1-3
1-8	Equipment Data	1-5
1-9	Safety, Care and Handling	1-5
1-10	Difference Between Models.....	1-6

1-6. Equipment Characteristics, Capabilities, and Features. A summary of the characteristics, capabilities and features of the equipment is as follows:

a. 10,000 and 25,000 lb. Sling Assembly Characteristics. The sling assemblies provide a capability to move cargo loads from point-to-point using aircraft..

b. 10,000 and 25,000 lb. Sling Assembly Capabilities and Features.

- (1) 10,000 and 25,000 lb. maximum weight capacity.
- (2) Each leg carries ¼ of the total weight.
- (3) One to six legs may be combined for use.
- (4) Every tenth link is painted olive drab.

c. 5,000 and 10,000 lb. Cargo Net Characteristics. Provides a capability to externally transport general cargo.

d. 5,000 and 10,000 lb. Cargo Net Capabilities and Features.

- (1) 5,000 and 10,000 lb. maximum weight capacity.
- (2) Cubic capacity of 5,000 lb. net is 125 cu ft.
- (3) Cubic capacity of 10,000 lb. net is 380 cu ft.

1-7. Location and Description of Major Components. The following subparagraphs contain locations and descriptions of major components

a. 10,000 and 25,000 lb. External Transport Slings. The 10,000 and 25,000 lb. slings (figure 1-2) consist of an apex fitting and four nylon rope legs At the lower eye of each leg, the grabhook is attached Each grabhook has an 8 foot chain that allows for 0 to 4 foot adjustments

b. 5,000 and 10,000 lb External Transport Cargo Nets. The 5,000 and 10,000 lb. cargo nets (figure 1- 3) consists of an octagon shaped nylon net. There are four sets of lifting legs used with each net. Each leg is made from 1 ¾ inch wide nylon webbing stacked in four layers. They are attached to the outside of the net. Each leg is 11 feet long with a hook at the apex An apex. fitting is attached to a leg assembly by a nylon tether cord.

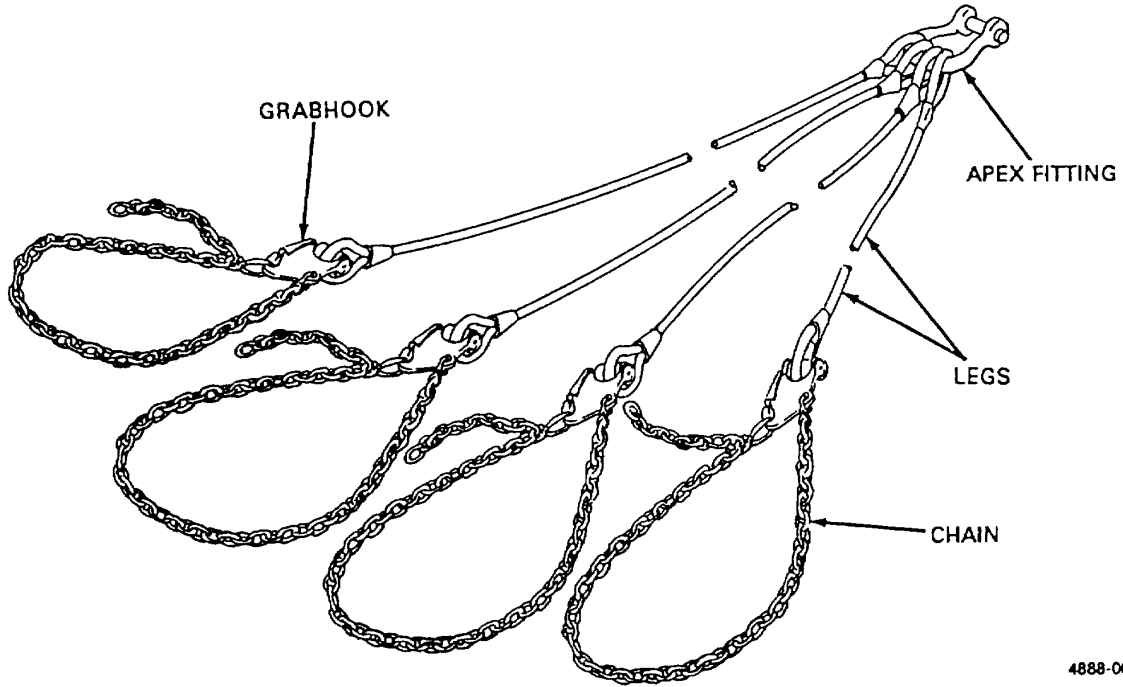

4888-001

Figure 1-2. 10,000 and 25,000 lb. External Transport Slings.

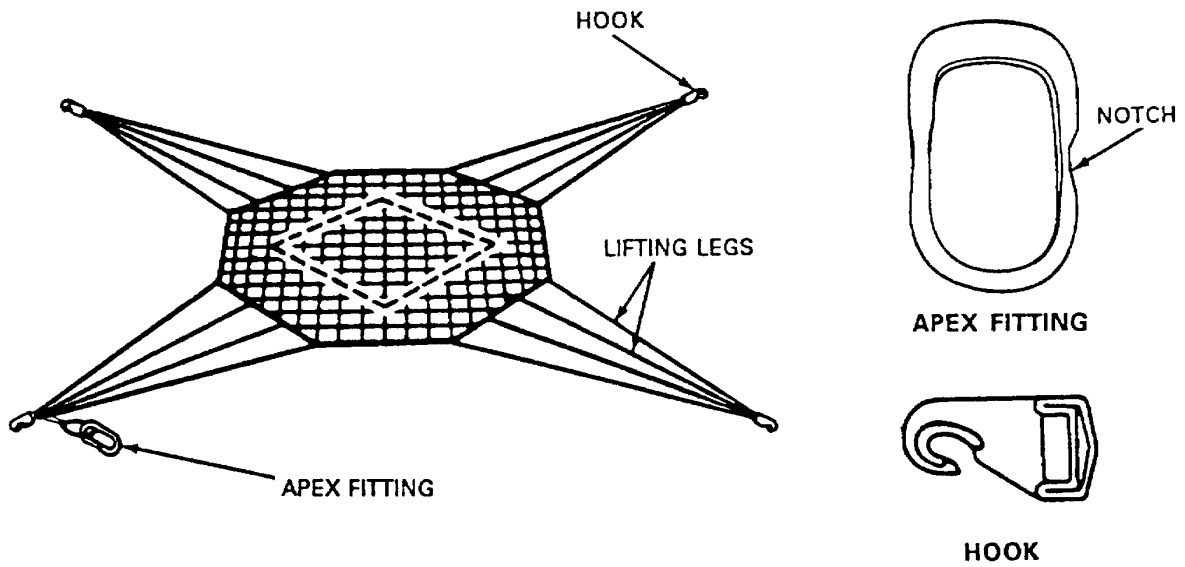

4888-002

Figure 1-3. 5,000 and 10,000 lb. External Transport Cargo Nets.

1-8. **Equipment Data.** The following list summarizes the specific capabilities and limitations of the equipment and other critical data needed by unit and intermediate direct support (DS) maintenance of 10,000 and 25,000 lb. External Transport Slings and 5,000 and 10,000 lb. External Transport Cargo Nets.

a. 10,000 lb. Slings.

Weight Capacity.....	10,000 lb. max.
Number of Legs	4
Length of Legs	12 ft.
Total Weight	52 lb.
Number of Chain Lengths.....	111

b. 25,000 lb. Slings.

Weight Capacity.....	25,000 lb. max.
Number of Legs	4
Length of Legs	12ft.
Total Weight	114 lb.
Number of Chain Lengths.....	88

c. 5,000 lb. Cargo Nets.

Weight Capacity.....	5,000 lb. max.
Number of Legs	4
Length of Legs	12 ft.
Materiel.....	Nylon
Cubic Capacity.....	125 cu ft.
Total Weight	58 lb.
Dimensions	15 ft. x 15 ft.

d. 10,000 lb. Cargo Nets.

Weight Capacity.....	10,000 lb. max.
Number of Legs	4
Length of Legs	11 ft.
Materiel.....	Nylon
Cubic Capacity.....	380 cu ft.
Total Weight	96 lb.
Dimensions	18 ft. x 18 ft.

1-9. **Safety, Care, and Handling.**

a. Safety. It is imperative that you observe all safety precautions specified on the warning page in the front of this manual. You must also observe specific warnings and cautions specified throughout this manual. The warnings are provided to tell you how to protect yourself from death or serious injury.

b. Care and Handling.

- (1) Use care in handling packing sling or cargo nets as metal parts can cause personal injury.
- (2) Use every effort to protect the slings or cargo nets from the weather elements, dust, dirt, oil grease, acids, and direct sunlight.
- (3) Avoid exposing legs or nets to prolonged exposure to sunlight, inspection lights or fluorescent lights. Nylon material is subject to deterioration under ultraviolet light.
- (4) Use a heated building to store slings and cargo nets when available. Store slings and cargo nets in a dry, well ventilated location, protected from pilferage, dampness, fire dirt, insects, rodents, and direct sunlight.

1-10. **Equipment Differences.**

- a. 10,000 and 25,000 lb. Sling Assemblies. Visible differences are shown in Table 1-1.

Table 1-1. Visible Differences Between the 10,000- and 25,000-Pound Capacity Sling Set.

Item	10,000-lb. Capacity	25,000-lb. Capacity
Sling rope color	Olive drab	Black
Sling rope diameter	7/8-inch	1 ¼ inches
Clevis color	Dull gray aluminum	Gold steel
Number chain links	111 (approximate)	88
Weight	52 pounds	114 pounds

- b. 5,000 and 10,000 lb. Cargo Net Assemblies. Visible differences are shown in table 1-2

Table 1-2. Visible Differences Between the 5,000-and 10,000-Pound Capacity Cargo Net Sets.

Item	5,000-lb. Capacity	10,000-lb. Capacity
Net size	15-feet	18-feet
Mesh size	6-inches	7.5-inches
Load zone	5-foot square	6-foot square
Weight	58 pounds	96 pounds

SECTION III. PRINCIPLES OF OPERATION

The operation of external transport equipment is outlined in FM 55-450-1.

CHAPTER 2

UNIT AND INTERMEDIATE DIRECT SUPPORT (DS)
MAINTENANCE FUNCTIONS

	Page
Section I. Repair Parts, Special Tools, TMDE, and Support Equipment.....	2-1
Section II Service Upon Receipt.....	2-2
Section III Unit Preventive Maintenance Checks and Services.....	2-2
Section IV Unit and Intermediate Direct Support (DS) Maintenance Procedures.....	2-5
Section V External Transport Sling Assembly Repair.....	2-12
Section VI External Transport Cargo Nets Repair.....	2-43
Section VII Preparation for Storage or Shipment.....	2-65

OVERVIEW

This chapter contains information necessary to maintain the 10,000 and 25,000 lb. slings and the 5,000 and 10,000 lb. cargo nets on the unit and Intermediate direct support (DS) maintenance levels in accordance with the Maintenance Allocation Chart (MAC) (Appendix B). It includes the following:

- a. Procedures for processing a new or used slings and cargo nets upon receipt.
- b. Assembly of components.
- c. Preventive maintenance procedures to ensure continued serviceability of all components.
- d. As required inspections and maintenance procedures performed prior to use such as cleaning and painting.
- e. Repair methods and repair or replacement procedures for all components of the slings and cargo nets.

SECTION I. REPAIR PARTS, SPECIAL TOOLS, TEST MEASUREMENT AND DIAGNOSTIC EQUIPMENT (TMDE), AND SUPPORT EQUIPMENT

Paragraph		Page
2-1	Common Tools and Equipment	2-1
2-2	Special Tools, TMDE and Support Equipment.....	2-1
2-3	Repair Parts.....	2-2

2-1. **Common Tools and Equipment.** For authorized common tools and equipment, refer to the Modified Table of Organization and Equipment (MTOE) applicable to your unit and Appendix B, Section III of this manual.

2-2. **Special Tools, TMDE and Support Equipment.** Special Tools, TMDE and Support Equipment are not required.

2-3. **Repair Parts.** Repair parts are listed and illustrated in Appendix C of this manual.

SECTION II. SERVICE UPON RECEIPT

Paragraph	Page
2-4 Initial Receipt.....	2-2
2-5 Checking Unpacked Equipment After Shipment.....	2-2

2-4. **Initial Receipt.** The following describes the procedures for processing external transport equipment upon initial receipt

a. General Procedures. When the external transport equipment is initially procured from a supply source and issued to a using unit, the item(s) will be unpacked from the shipping container(s) and inspected. The inspection performed will be for completeness which will be conducted as outlined in paragraph 2-8. Upon completion of the inspection, the item(s) will be tagged as prescribed in DA PAM 738-751. Serviceable equipment may then be entered either into storage or into use in operations, as applicable. An unserviceable item will be held and reported in accordance with DA PAM 738-751.

b. Configuration/Condition. Acceptance of new equipment from the manufacturer is based upon inspections made of sample lots which have been randomly selected in accordance with military standards. It is incumbent upon the using activity personnel to bear this in mind whenever equipment is first placed in service. Changes will sometimes evolve from the original equipment design and sometimes contracts are authorized to make deviations in material and construction techniques. External transport equipment that has been in the field cannot be expected to meet exacting manufacturing specifications; however, the equipment should closely reflect desired design characteristics. Since repairs, modifications, and/or changes can alter or detract from the configuration originally desired, such equipment shall be air worthy, safe, of the desired configuration, and adequate for intended use.

2-5. Checking Unpacked Equipment After Shipment.

a. Inspect equipment for damage incurred during shipment. If the equipment has been damaged, report the damage on SF Form 364, Packing Improvement Report

b. Check the equipment against the packing slip to see if the shipment is complete. Report all discrepancies in accordance with the instructions in DA PAM 738-750.

SECTION III. UNIT PREVENTIVE MAINTENANCE CHECKS AND SERVICES (PMCS)

Paragraph	Page
2-6 PMCS Procedures.....	2-2

2-6. **PMCS Procedures.** The following describes PMCS procedures of the unit level:

a. General. Table 2-1 and 2-2 lists preventive maintenance checks and services. The purposes of PMCS is to assure that the sling assemblies and cargo nets are operational.

b. Frequency of Performing PMCS. PMCS will be performed before equipment is used before modification and repair, after use, or at any time deemed necessary by the unit maintenance officer.

c. PMCS Columnar Entries Table 2-1 and 2-2. The following is a list of PMCS table column headings with a description of the information found in each column.

(1) *Item number*. This column shows the sequence in which to do the checks and services, and is used to identify the equipment area on the Equipment Inspection and Maintenance Worksheet, DA Form 2404.

(2) *Interval*. This column shows when each check is to be done.

(3) *Item to be inspected*. This column identifies the general area or specific part where the check or service is to be done.

(4) *Procedures*. This column lists the checks or service you have to do and explains how to do them.

d. Recording Defects. All defects discovered during the inspection will be recorded using the applicable specifics in DA PAM 738-750, DA PAM 738-751.

e. Inspection Function Requirement. Normally, a technical inspection will be performed by maintenance personnel or repair activity. The inspection of initial receipt items will be performed as a separate function from using activity, the item to be inspected will be placed in proper layout on a suitable sized floor area. Should defect or damage be discovered at any point during the inspection, the inspection will be terminated and the applicable item will be processed and forwarded to repair activity. The repair activity, in turn, will conduct a technical inspection. Any defect discovered during a unit level repair activity inspection which exceeds the capability of that activity will require the affected item to be evacuated to an intermediate maintenance function for further determination of economic repair and repair accomplishment, if applicable.

Table 2-1. Unit Preventive Maintenance Checks and Services (PMCS) for External Transport Sling Assembly.

Item No	Interval			Item To Be Inspected	Procedures
	B	D	A		
1	•	•	•	External Transport Slings	Inspect for burrs, bends, cracks and missing parts.
				Apex Fitting	
				Apex Spacer/Pin	
2	•	•	•	Bolt/Nut/Cotter Pin	Corrosion, rough spots, burrs, bolt bent or broken, nut missing, cotter pin missing or broken.
				Sling Leg	
3	•	•	•	Grabhook Assembly	Cut or rubs in polyurethane coating, rubbed or frayed yarn, cut on external and core braided rope.
				Keeper/Bolt/Nut/Spacer/Snap Ring	
4	•	•	•	Chain	Spreading or bending of the chain hook and missing parts.

Table 2-2. Unit Preventive Maintenance Checks and Services (PMCS) for External Transport Cargo Nets.

Item No	B-Before			D-During	A-After
	Interval			Item To Be Inspected	Procedures
	B	D	A		
1	•	•	•	External Transport Cargo Nets Apex Fitting	Corrosion, rough spots, burrs, breaks, cracks, bends.
2	•	•	•	Hook	Corrosion, rough spots, burrs, breaks, cracks, bends.
3	•	•	•	Lifting Leg Buffer	Completeness, dampness, fungus, dirt, acid, grease, oil, foreign material, rips, burns, cuts, breaks, frays, tears, holes, thin spots, loose weaving, loose or broken stitching.
4	•	•	•	Nets	Completeness, dampness, fungus, dirt, acid, grease, oil, foreign material, rips, burns, cuts, breaks, frays, tears, holes, thin spots, loose weaving, loose or broken stitching.

**SECTION IV. UNIT AND INTERMEDIATE DIRECT SUPPORT (DS)
MAINTENANCE PROCEDURES**

Paragraph	Page
2-7 General Information	2-5
2-8 Inspection.....	2-6
2-9 Painting.....	2-7
2-10 Searing	2-7
2-11 Cleaning and Drying.....	2-8

2-7. **General Information.** The following paragraphs contain the general information pertinent to unit and Intermediate direct support (DS) maintenance procedures:

a. Scope . This section contains maintenance procedures which are the responsibility of the specified technician as authorized by the Maintenance Allocation Chart (MAC) and the Source, Maintenance and Recoverability (SMR) coded items that are identified in the Repair Parts and Special Tools List (RPSTL).

b. Maintenance Functions/Procedures. Each paragraph identifies a maintenance function specified in the MAC. All maintenance procedures required to complete a maintenance function are identified under “This task covers”, in the order in which the work is most logically accomplished.

2-8. Inspection.**NOTE**

Neither initial nor periodic proof load testing of the 10,000 and 25,000 lb. capacity sling is required to be performed by using units.

a. *Sling Assembly.* Before using a sling set, inspect all metalware for proper operation, rust, corrosion, cracks, bends, distortions, burrs, sharp edges, grease, oil, acid, or foreign matter. Check for any missing components. If bends, cracks, or distortions are present, the sling cannot be used. If any of the maximum criteria is exceeded, the rope must be replaced. Do not be alarmed if fuzziness appears on the rope. This is one of the characteristics of nylon and does not affect the strength of the rope.

Outer jacket yarns in the 10,000-pound capacity rope are identified by a braided strand about three-thirty seconds of an inch in diameter. In the 25,000-pound capacity rope, yarns are identified by a braided strand about one-eighth inch in diameter. Refer to the Maintenance Allocation Chart (MAC) when replacing components.

b. *Cargo Nets.* First spread out the net flat on the ground. Make sure the lifting legs are pulled free of the body of the net. Inspect each hook for burrs, cracks, and distortions. Begin the inspection with the hook next to the apex fitting. Then check the other three hooks, ending with the hook that has the apex fitting attached to it. Use a metal file to smooth out any burrs. Burrs could snag or cut into the net. Corrective action now will prevent having to replace or repair major portions of the net later. Nets with badly damaged or missing metal hooks must be returned to the direct support unit for replacement.

2-9. Painting.

This task covers: Painting

Tools:

Personnel Required:

Brush, paint, 1-in Item 1, Appendix B

Materials/Parts:

Paint, OD, Item 16, Appendix D

Painting.

- (1) Count ten links from end of chain.
 - (2) Using a 1-in. paint brush and olive drab paint permanently paint tenth links of chain.
 - (3) Repeat for each subsequent tenth link.
-

2-10. Searing.

This task covers: Searing

Tools.

Electric Pot, Melting, Item 7, Appendix B

Knife, Metal, Hot, Item 4, Appendix B

NOTE

Fabric materials such as cord, tape, and webbing that are cut for use in the maintenance of parachutes will normally be heat-seared, to prevent the material from fraying or unraveling. However, in some instances the preparation of the material may not be necessary and will be specified accordingly.

Searing. The cut ends of nylon tape, webbing, and cord lengths may be prepared by heat-searing which is performed by pressing the raw end of the material against a hot metal surface (knife) until the nylon has melted sufficiently. Avoid forming a sharp edge or lumped effect on the melted end.

2-11. Cleaning and Drying.

This task covers:

- | | |
|--|--|
| <ul style="list-style-type: none"> a. Cleaning fabric items with cleaning solvent b. Cleaning fabric items with dishwashing compound | <ul style="list-style-type: none"> c. Drying fabric items d. Cleaning metal items e. Equipment immersed in salt water f. Equipment immersed in fresh water |
|--|--|

Materials/Parts:

Tetrachloroethylene, Item 12, Appendix D
 Dishwashing Compound, Item 9, Appendix D
 Rag, Wiping, Item 11, Appendix D
 Lubricant, Solid Film, Item 10, Appendix D
 Cloth, Abrasive, Item 3, Appendix D
 Brush, Scrub, Item 1, Appendix D
 detrimental to health

Equipment Condition:

Layout on packing table or other suitable area

Special Environmental Condition.

Ventilation required as repeated or prolonged inhalation of cleaning solvent vapors can be detrimental to health

WARNING

Due to flammable properties and nylon-damaging substances, cleaning solvents other than tetrachloroethylene will not be used in the spot-cleaning. Tetrachloroethylene will only be used in areas where substantial ventilation is available. Repeated or prolonged Inhalation of the solvent vapors can be detrimental to human health. In addition, avoid prolonged or repeated contact of the solvent fluid with areas of the skin. Tetrachloroethylene must not be taken internally.

CAUTION

If during the cleaning there exists a possibility that the substance to be removed contains acid or some other equally destructive ingredient, the item will be evacuated to intermediate maintenance activity for determination as to the nature of the substance and item disposition. If the substance cannot be identified or if normal repair procedures will not eliminate all traces of chemical or acid damage, the applicable item will be condemned.

NOTE

Cleaning of external transport equipment should be held to a minimum and should be performed only when necessary to prevent malfunction or deterioration. When external transport equipment contains debris, or when it is soiled by dirt, oil, grease, rust, corrosion, or other foreign substances to such an extent that cleaning is necessary, the cleaning should be performed manually and should be limited to the soiled area only, unless the equipment has been contaminated by water. The methods of cleaning must be determined by the nature of the substance to be removed

NOTE

Do not use cleaning solvent to clean item soiled caused by air sickness. Use a solution of hand dishwashing compound to clean this type of soiling.

a. Cleaning Fabric Items with Cleaning Solvent. Use cleaning solvent to clean fabric items as follows:

- (1) Gently brush with a soft. bristle brush.
- (2) Spot clean with cleaning solvent tetrachloroethylene.
 - (a) Rub soiled area with a clean cloth dampened with tetrachloroethylene.
 - (b) Rinse cleaned area by repeating the rubbing process with clean portion of clean cloth dampened with the cleaning solvent.

NOTE

Do not wring out the rinsed area If an excessive amount of cleaning solvent was applied.

b. Cleaning Fabric items with a Solution of Hand Dishwashing Compound. Use dishwashing compound to clean fabric items as follows:

- (1) Gently brush with a soft. bristle brush.
- (2) Spot clean with a solution of dishwashing compound.
 - (a) Dissolve 1/2 cup of dishwashing compound in one gallon warm water.
 - (b) Rub soiled area with clean cloth dampened with solution of dishwashing compound.
 - (c) Rinse cleaned area by repeating rubbing process with a clean portion of cloth dampened with the dishwashing compound.

NOTE

Fabric items will not be dried in direct sunlight or by laying an item on the ground.

c. Drying Fabric Items. Dry fabric items as follows:

- (1) Suspend or elevate item in a well-ventilated room or in a heated drying room.
- (2) Drying time may be reduced by using electric circulating fans.
- (3) When heat is used, the heat temperature shall not exceed 160°F (71°C). Preferred temperature is 140°F (60°C).

2-11. **Cleaning and Drying (cont).**

- d. Cleaning Metal Items. Clean metal items as follows:

CAUTION

Use care not to damage the adjacent fabric materials.

- (1) Remove burrs, rough spots, rust or corrosion from metal items by filing with a metal file or by buffing and polishing with abrasive cloth

WARNING

Use tetrachloroethylene only in areas where substantial ventilation is provided. Repeated or prolonged inhalation can be detrimental to human health. Avoid prolonged or repeated contact with skin areas. Tetrachloroethylene must not be taken internally.

- (2) Remove all oils and filings by brushing and dipping in tetrachloroethylene. Allow to dry.

NOTE

Shield adjacent fabric material before spraying solid film lubricant.

- (3) Spray metal item with a film lubricant and allow to air dry for 24 hours.

NOTE

A small amount of lubricant will not damage fabric, but may cause discoloration and make fabric appear soiled.

- e. Equipment Immersed in Salt Water. Items found or known to be contaminated are to be cleaned in the following manner.

- (1) Place equipment in a large water-tight container filled with a suitable amount of fresh, clean water to cover item(s)

CAUTION

Equipment made of cotton, fabric such as the buffer, immersed in salt water are to be condemned. See paragraph 1-3, for equipment disposition.

NOTE

If salt water-soaked equipment is too large to be placed in a rising container, then the rising process will be effected by applying fresh, clean water to the item using a hose.

- (2) Agitate container contents by hand for 5 minutes.

- (3) Remove item(s) from container and suspend or elevate equipment in a shaded area, allowing a 5-minute drainage period. Do not attempt to wring equipment fabric.
 - (4) Repeat procedures (1) through (3) about twice, using fresh, clean water for each rinse.
 - (5) After third rinse, allow equipment to drain thoroughly. Upon completion of draining, dry equipment.
 - (6) When dried, perform a technical type inspection. If item(s) have corroded metal components, or corrosion-stained fabrics they will be either repaired or replaced as prescribed by Maintenance Allocation Chart (MAC) (Appendix B).
- f. Equipment Immersed in Fresh Water. Any external transport equipment that has been immersed in freshwater lake, river or stream will not require rising unless it has been ascertained that the water is dirty, oily or otherwise contaminated. Procedures for handling fresh water immersed equipment are as follows:
- (1) Contaminated fresh water. If the external transport equipment has been immersed in contaminated fresh water, rinse, dry and, if applicable, repair the item(s).
 - (2) *Uncontaminated fresh water.* If external transport equipment has been immersed in uncontaminated fresh water, item(s) will be cleaned and dried as outlined in this paragraph. Minor discoloration of fabric items resulting from immersion in uncontaminated fresh water may occur. No attempt should be made to eliminate a minor discoloration as a slight discoloring is preferable to employing vigorous techniques that may damage fabric. Small stains caused by petroleum products or blood will be removed using spot-cleaning procedures in this paragraph.

SECTION V. EXTERNAL TRANSPORT SLING ASSEMBLY REPAIR

Paragraph		Page
2-12	Apex Fitting	2-12
2-13	Apex Spacer.....	2-13
2-14	Apex Pin.....	2-14
2-15	Bolt.....	2-15
2-156	Nut	2-15
2-16	Nut	2-16
2-17	Cotter Pin	2-17
2-18	Sling Leg	2-18
2-19	Grabhook Assembly	2-20
2-20	Keeper	2-22
2-21	Keeper Bo	2-23
2-22	Grabhook Spacer	2-24
2-23	Snap Ring	2-25
2-24	Coupler Link	2-26
2-25	Chain.....	2-27
2-26	Storage Bag	2-28

2-12. Apex Fitting Assembly

This task covers:**a. Inspect**
d. Replace**b. Service****c. Repair**

*Tools:**Equipment Condition:*

File, Metal, Item 2, Appendix B

On work table

- a. Inspect.* Refer to paragraph 2-8 for Inspection procedures.
- b. Service.* Refer to paragraph 2-6 for service procedures.
- c. Repair.* Remove burrs, rough spots, rust or corrosion from apex fitting by filing with a metal file or buffing with abrasive cloth.
- d. Replace.* Replace an unserviceable/unreparable apex fitting with one from stock.

2-13. Apex Spacer.

This task covers:**a. Inspect****b. Repair****c. Replace**

Tools:

File, Metal, Item2, Appendix B

*Equipment Condition:*Apex pin removed (para. 2-14)

- a. Inspect. Refer to paragraph 2-8 for inspection procedures.
- b. Repair. Remove burrs, rough spots, rust or corrosion from apex spacer by filing with a metal file or buffing with abrasive cloth.
- c. Replace. (figure 2-1).
- (1) Remove apex spacer (1) from apex (2).
 - (2) Hold apex spacer (1) in between apex (2).

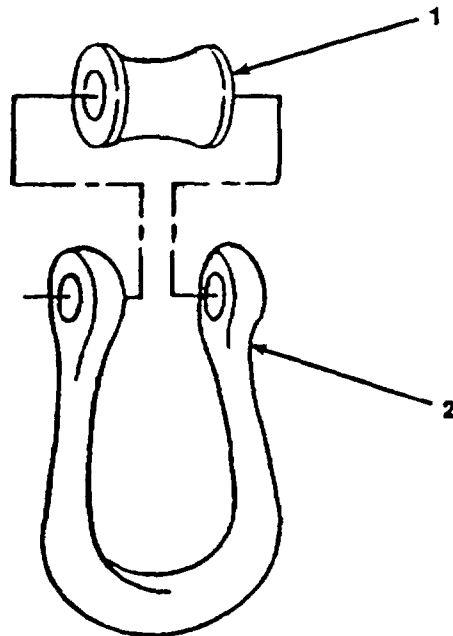

Figure 2-1 . Apex Spacer Replacement

FOLLOW-ON MAINTENANCE
Install apex pin (para 2-14).

2-14. Apex Pin.

This task covers:**a. Inspect****b. Repair****d. Replace**

Tools:

File, Metal, Item2, Appendix B

*Equipment Condition:*Bolt removed (para. 2-15).

- a. Inspect. Refer to paragraph 2-8 for inspection procedures.
- b. Repair. Remove burrs, rough spots, rust or corrosion from apex pin by filing with a metal file or buffing with abrasive cloth.
- c. Replace. (figure 2-2).
- (1) Hold apex spacer (1) and remove apex pin (2).
- (2) Slide apex pin (2) through apex (3) and apex spacer (1).

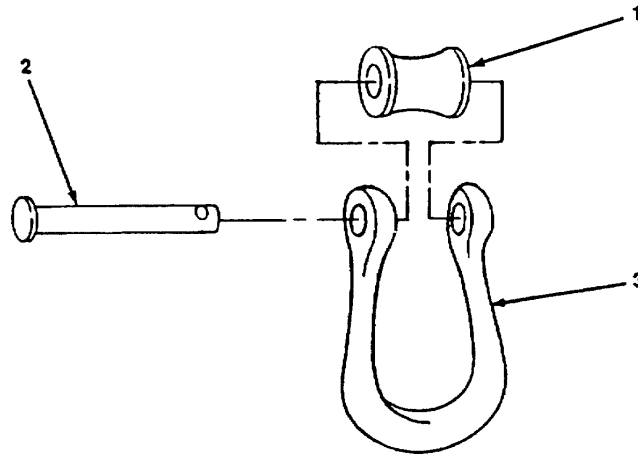

Figure 2-2 . Apex Pin Replacement .

FOLLOW-ON MAINTENANCE
Install bolt (para 2-15)

2-15. Bolt.

This task covers:**a. Inspect****b. Replace**

*Equipment Condition.*Nut removed (para 2-16).

a. Inspect. Refer to paragraph 2-8 for inspection procedures.

b. Replace (figure 2-3)

(1) Slide bolt (1) out of apex pin (2)

(2) Install bolt (1) on apex pin (2).

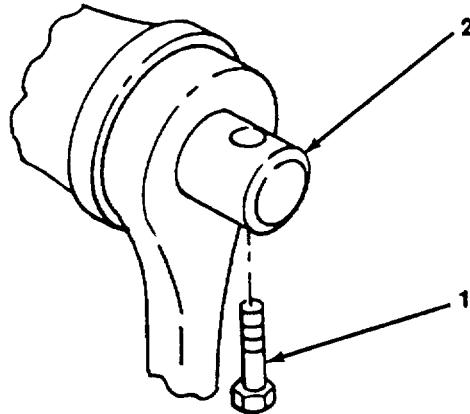

488-035

Figure 2-3. Bolt Replacement

FOLLOW-ON MAINTENANCE:
Install nut (para. 2-16)

2-16. Nut.

This task covers:**a. Inspect****b. Replace**

*Equipment Condition:*Cotter pin removed (para. 2-17)

a. *Inspect.* Refer to paragraph 2-8 for inspection procedures

b. *Replace.* (figure 2-4)

(1) Remove nut (1) from bolt (2)

(2) Install nut (1) on bolt (2).

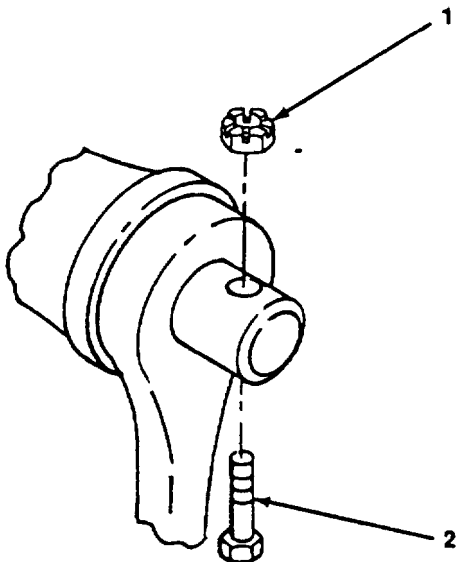

Figure 2-4. Nut Replacement

FOLLOW-ON MAINTENANCE:
Install cotter pin (para 2-17)

2-17. Cotter Pin

This task covers:**a. Inspect****b. Replace**

Replace . (figure 2-5)

- (1) Unbend and remove cotter pin (1)
- (2) Install cotter pin (1) In nut (2) and bend.

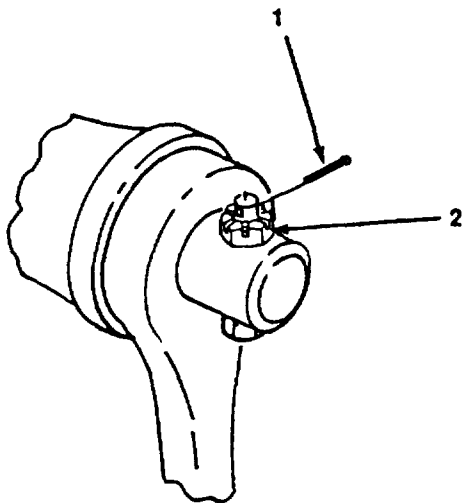

488-037

Figure 2-5. Cotter Pin Replacement.

2-18. Sling Leg.

This task covers:**a. Inspect****b. Replace**

Tools:

Pliers, Snap, Item 6, Appendix B

*Equipment Condition:*Bolt removed (para 2-15).
Keeper removed (para 2-20)

- a. Inspect. Refer to paragraph 2-8 for inspection procedures.
- b. Replace. (figure 2-6).
 - (1) Holding apex spacer (1), remove apex pin (2).
 - (2) Remove damaged sling leg (3) from apex (4).
 - (3) Trace damaged sling leg (3) to grabhook (5).
 - (4) Using snap hook pliers, remove snap ring (6).
 - (5) Holding spacer (7), remove pin (8) from grabhook (5).
 - (6) Remove sling leg (3).
 - (7) Position spacer (7) In eye of sling leg (3).
 - (8) Position in grabhook (5) and slide pin (8) in place, and secure with snap ring (6).
 - (9) Place sling leg (3) onto apex fitting (4).
 - (10) Install spacer (1) and pin (2).

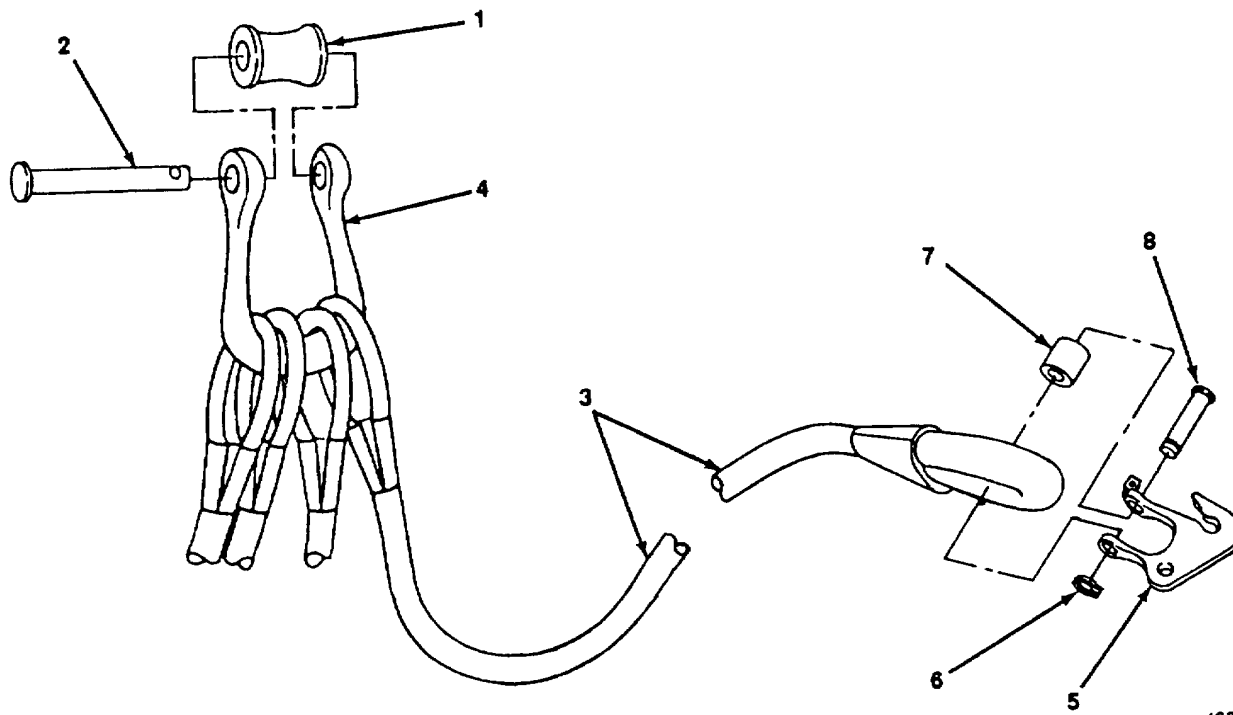

4888-005

Figure 2-6. Sling Leg Replacement

FOLLOW-ON MAINTENANCE:
Install bolt (para 2-15)
Install keeper (para 2-20)

2-19. Grabhook Assembly

This task covers:**a. Inspect****b. Repair****c. Replace**

Tools:Pliers, Snap, Item 6, Appendix B
Punch, Item 8, Appendix B**Equipment Condition:**On work table

- a. Inspect. Refer to paragraph 2-8 for inspection procedures.
- b. Repair. Repair of grabhook consists of replacing the keeper and the coupler.
- (1) Replace keeper (figure 2-7) (Refer to paragraph 2-20.).
 - (a) Remove nut (1), and bolt (2).
 - (b) Remove keeper (3) and spring (4).
 - (c) Position spring (4) in new keeper (3) and onto grabhook (5).
 - (d) Slide bolt (2) through grabhook spring (4) and keeper (3) and tighten nut (1).

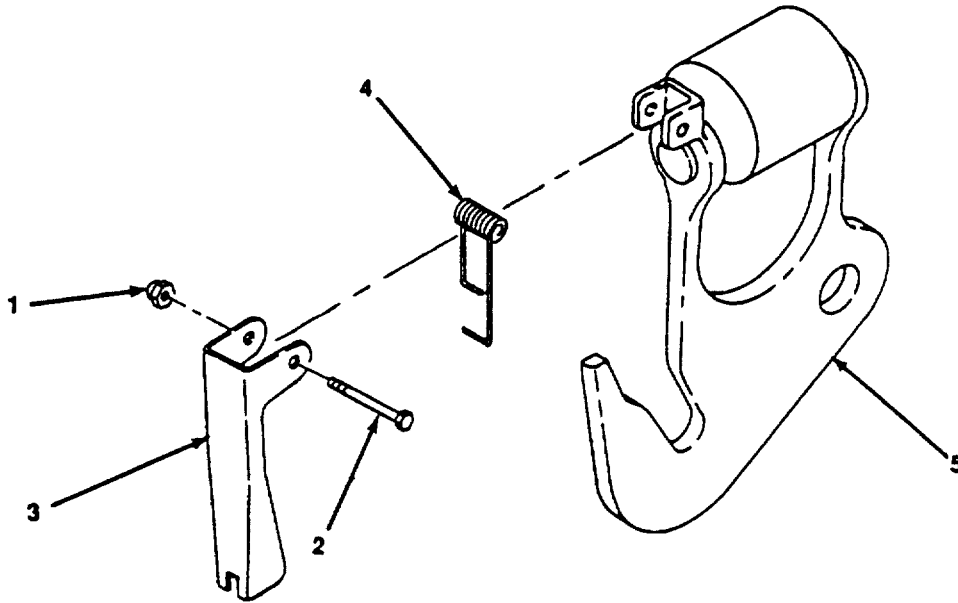

Figure 2-7. Grabhook Keeper Replacement

4888-007

(2) Replace coupler link (figure 2-8) and (para 2-24).

- (a) Using punch remove pin (1) from coupling link (2).
- (b) Separate and remove the coupling link (2) lower half bolt and spacer (3).
- (c) Remove remaining coupler link (2) half.
- (d) Install new coupler link half on grabhook (4).
- (e) Position spacer (3) and remaining coupler half and slide pin (1) into place on grabhook (4).

c. Replace. Replace an unserviceable/unrepairable grabhook with one from stock.

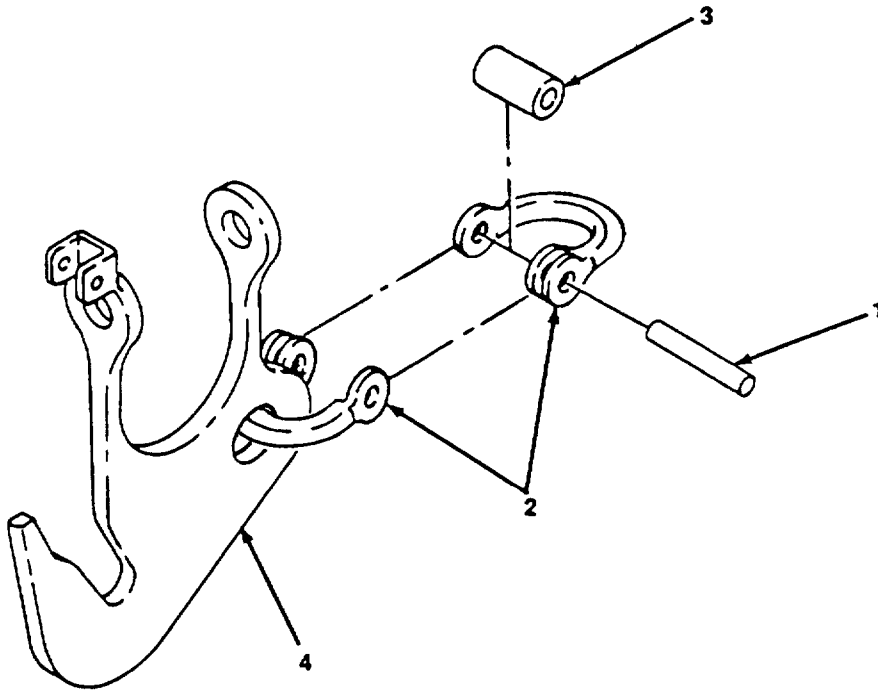

4888-008

Figure 2-8. Grabhook Coupler Link Replacement

2-20. Keeper**This task covers:****a. Inspect****b. Repair****c. Replace***Equipment Condition:*

Laid out on work table

- a. Inspect. Refer to paragraph 2-8 for inspection procedures.
- b. Repair. Repair burrs or rough edges by filing keeper with a metal file until smooth.
- c. Replace. (figure 2-9)
 - (1) Remove nut (1) and bolt (2).
 - (2) Tilt grabhook (3) to let keeper (4) and spring (5) fall out.
 - (3) Insert spring (5) in keeper (4) and leave keeper on outside of grabhook (3).
 - (4) Depress one end of the bolt (2) ends through one side of keeper (4) and grabhook (3).
 - (5) Before the bolt (2) starts through the grabhook (3), press the keeper (4) to one side of grabhook (3).
 - (6) Push keeper (4) under hook (3) until the notch cut is in center of keeper (4).
 - (7) Push bolt (2) completely through spring (5) and keeper (4) onto grabhook (3).
 - (8) Secure keeper (4) by tightening nut (1).

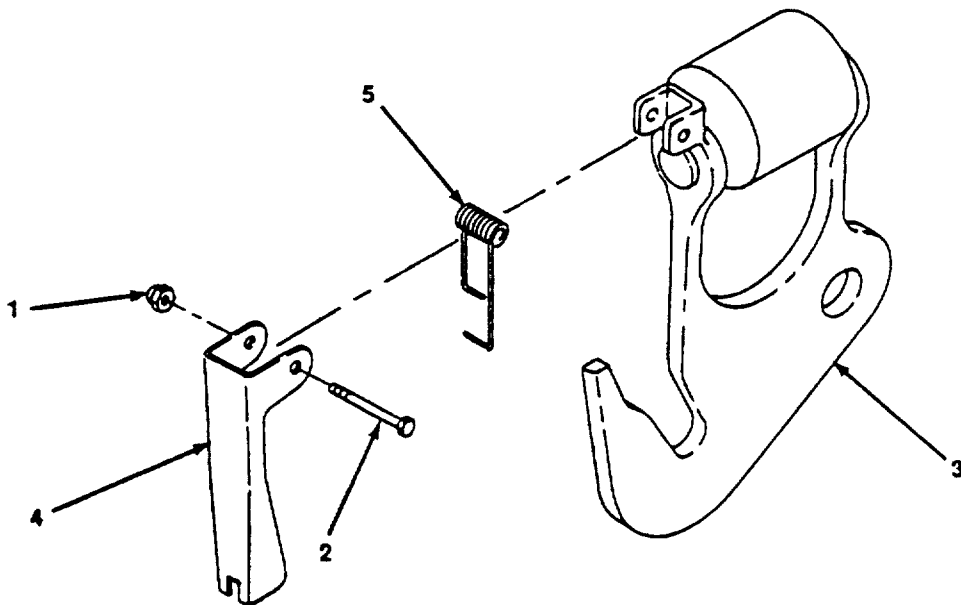

Figure 2-9. Keeper Replacement

4888-009

2-21. Keeper Bolt.

This task covers:**a. Inspect****b. Replace**

*Equipment Condition:*Laid out on work table

a. Inspect. Refer to paragraph 2-8 for inspection procedure.

b. Replace. (figure 2-10).

(1) Unscrew nut (1) and remove the bolt (2).

(2) Insert bolt (2) into keeper (3) and tighten nut (1).

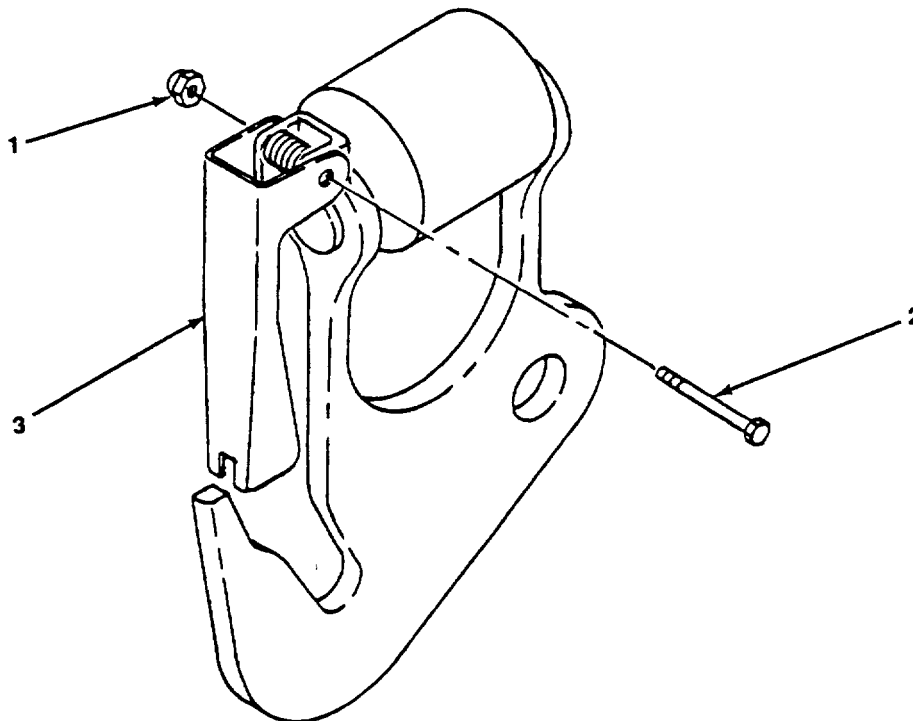

4888-038

Figure 2-10. Keeper Bolt Replacement

2-22. Grabhook Spacer.

This task covers:**a. Inspect****b. Replace**

Tools:

Pliers, Snap, Item 6, Appendix B

*Equipment Condition:*Keeper removed (para 2-20)
Snap ring removed (para. 2-23)

- a. Inspect. Refer to paragraph 2-8 for Inspection procedures.
- b. Replace. (figure 2-11).
- (1) Holding spacer (1), remove pin (2) from grabhook (3).
 - (2) Remove sling leg (4) from spacer (1).
 - (3) Install spacer (1) in eye of sling leg (4).
 - (4) Position spacer (1) in grabhook (3) and slide pin in place.

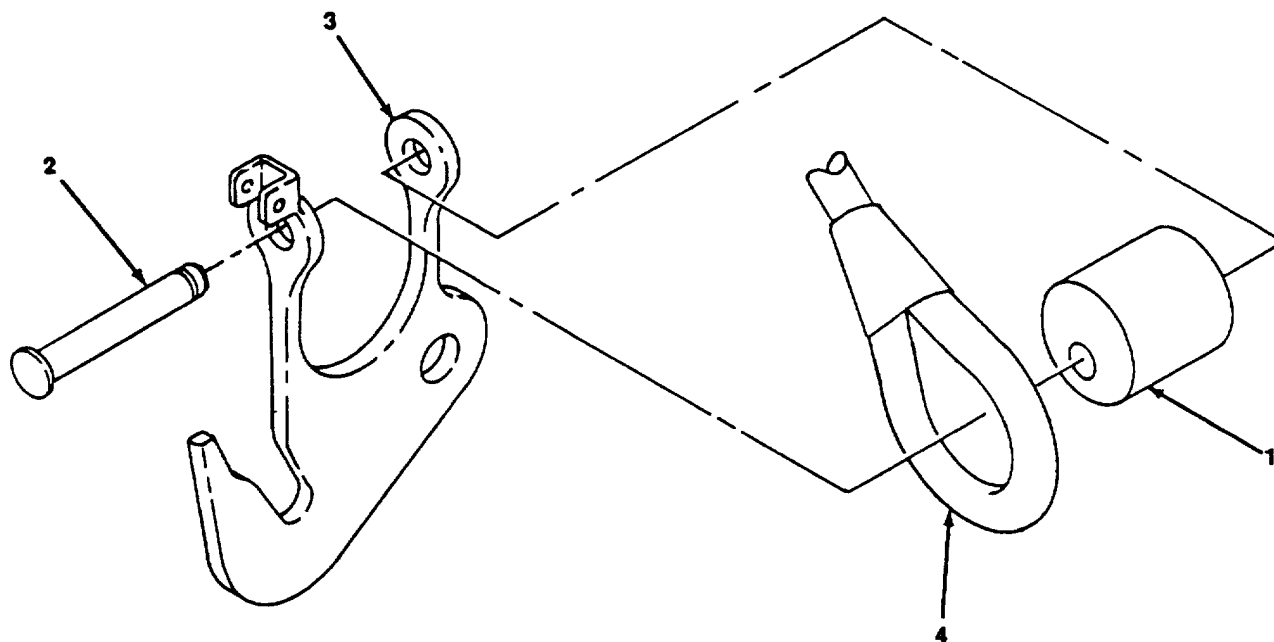

4888-010

*Figure 2-11. Grabhook Spacer Replacement.***FOLLOW-ON MAINTENANCE:**
Install Keeper (para 2-20)
Install Snap Ring (para 2-23)

2-23. Snap Ring

This task covers:**a. Inspect****b. Replace**

Tools:

Pliers, Snap, Item 6, Appendix B

*Equipment Condition:*On work table

a. *Inspect*. Refer to paragraph 2-8 for Inspection procedures.

b. *Replace*. (figure 2-12).

(1) Using snap pliers grasp ends of snap ring (1).

(2) Pull snap ring (1) off of apex pin (2).

(3) Install snap ring (1) onto apex pin (2) using snap plier.

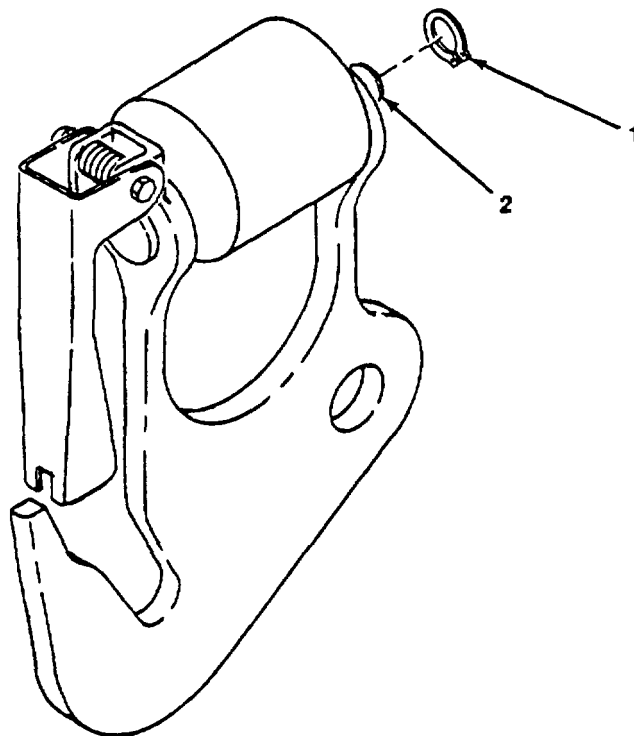

4888-039

Figure 2-12. Snap Ring Replacement

2-24. Coupler Link

This task covers:**a. Inspect****b. Replace**

*Tools:*Punch, Item 8, Appendix B
Hammer, Item 17, Appendix B*Equipment Condition:*On work table.

- a. *Inspect.* Refer to paragraph 2-8 for inspection procedures.
- b. *Replace.* (figure 2-13).
 - (1) Using punch remove pin (1) from coupling link (2).
 - (2) Separate and remove the coupling link half (2) and spacer (3).
 - (3) Remove chain from coupling link.
 - (4) Remove remaining coupler link half (2).
 - (5) Install new coupler link half (2) on grabhook (4).
 - (6) Attach chain to new coupler link half.
 - (7) Position spacer (3) and remaining half of coupler (2), and slide pin (1) into place on grabhook (4).

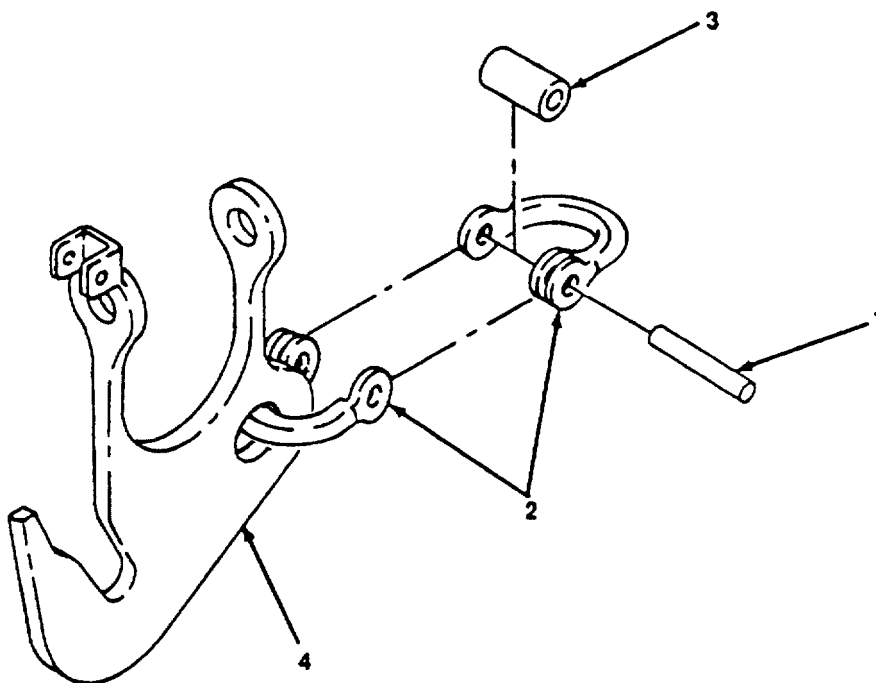

4888-040

Figure 2-13. Coupler Link Replacement.

2-25. Chain.

This task covers:**a. Inspect****b. Repair****c. Replace**

Tools:

Punch, Item 8, Appendix B
File, Item 2, Appendix B
Hammer, Item 17, Appendix B

Equipment Condition:

Laid out on work table.

- a. Inspect. Refer to paragraph 2-8 for Inspection procedures.
- b. Repair. Repair burrs or rough edges by filing chain links with a metal file until smooth.
- c. Replace. (figure 2-14).
 - (1) Remove chain (1) from grabhook hook (2).
 - (2) Using punch, remove pin (3) from coupling link (4).
 - (3) Remove lower half of coupling link (4), spacer (5) and chain (1).
 - (4) Slide chain (1) onto coupling link (4).
 - (5) Install coupling link (4) on grabhook (6) with pin (3).

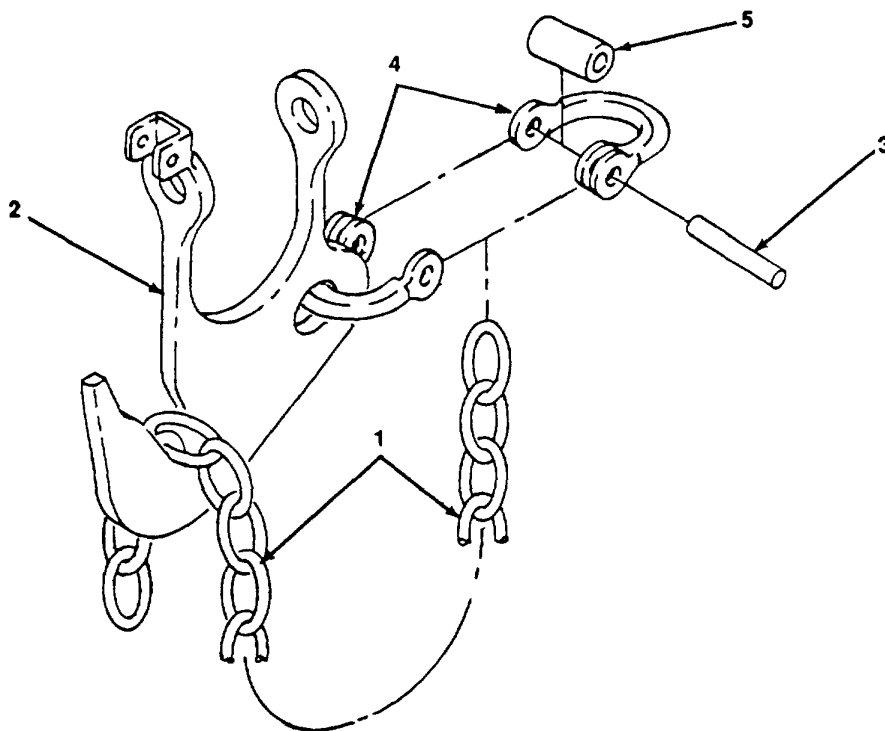

4888-011

Figure 2-14. Chain Replacement

2-26. Storage Bag.

This task covers:

a. Inspect

b. Replace

Equipment Condition:

Laid out on work table.

- a. Inspect. Inspect storage bag for broken or missing zippers, tears, loose stitching, holes and worn spots.
- b. Replace. Replace an unserviceable/unrepairable storage bag with one from stock

SECTION VI. EXTERNAL TRANSPORT CARGO NET REPAIR

Paragraph	Page
2-27 Apex Fitting	2-28
2-28 Hook.....	2-30
2-29 Lifting Leg.....	2-32
2-30 Buffer.....	2-35
2-31 Hook Keeper Strap	2-36
2-32 Net.....	2-38
2-33 Storage Bag.....	2-45

2-27. Apex Fitting.

This task covers:

a. Inspect

b. Repair

c. Replace

Tools:

File, Metal, Item 2, Appendix B
 Knife, Item 3, Appendix B

Equipment Condition:

On work table

Materials/Parts:

Cord, Nylon, Type III, Item 7, Appendix D

- a. Inspect. Run finger over entire apex fitting Inspect for burrs rough edges, distortions or cracks.
- b. Repair. Repair burrs or rough edges by filling apex fitting with a metal file until smooth

c. Replace. (figure 2-15)

- (1) Cut tether (1) and remove apex fitting (2).
- (2) Cut a 2-foot length of nylon cord.
- (3) Pass cord (tether) through new apex fitting (2) and lifting legs (3).
- (4) Tie tether (1) using a square knot and a locking knot.

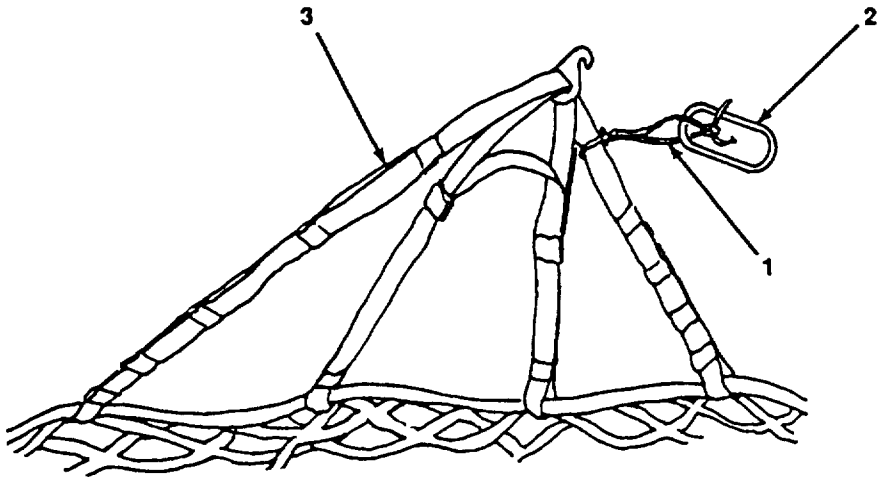

4888-012

Figure 2-15. Apex Fitting Replacement.

2-28. Hook.

This task covers:**a. Inspect****b. Repair****c. Replace**

Tools:

Knife, Item 3, Appendix B

*Equipment Condition:*Lifting leg removed (para 2-29)

- a. Inspect. Refer to paragraph 2-8 for inspection procedures.
- b. Repair. Repair burrs or rough edges by filing hook with a metal file until smooth.
- c. Replace. (figure 2-16)
 - (1) Cut stitching on hook keeper strap.
 - (2) Slide hook (1) off of lifting legs (2).
 - (3) Install hook (1) onto lifting legs (2).
 - (4) Restitch hook keeper strap (para 2-31).

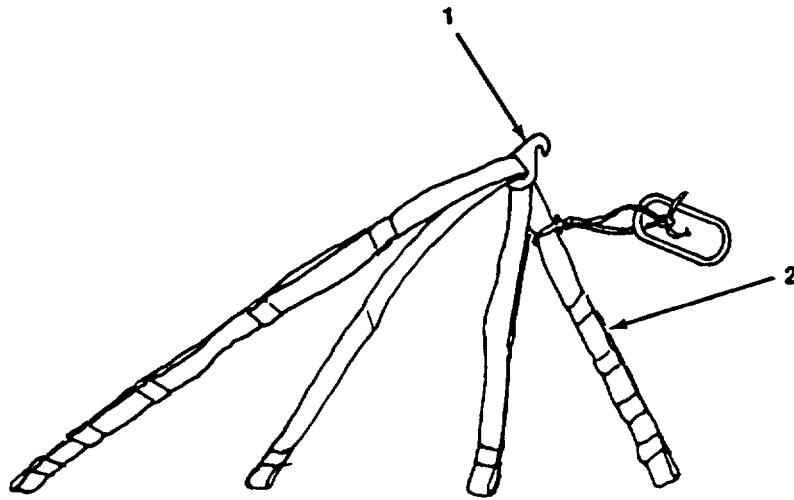

4888-019

Figure 2-16. Hook Replacement.

FOLLOW-ON MAINTENANCE:
Install lifting leg (para 2-29).

2-29. Lifting Leg.

This task covers:**a. Inspect****b. Repair****c. Replace**

Tools:

Knife, Item 3, Appendix B
 Knife, Hot Metal, Item 4, Appendix B
 Shears, Item 9, Appendix B
 Sewing Machine, Heavy Duty, Item 12, Appendix B
 Yardstick, Item 15, Appendix B

Equipment Condition:

Hook keeper strap removed (para 2-31)

Materials/Parts:

Webbing, Nylon, Type XXVI, Item 21, Appendix D
 Thread, Nylon, Size 6, Item 13, Appendix D

a. Inspect. To inspect the two lifting legs, start with the outside strap where it is looped and sewn around the border cord. Check stitching for damage or unraveling. Inspect the length of the lifting leg, place thumb on one side and index finger and middle finger on other. Run hand over entire length of webbing. If a cut or rub exceed 1/2 Inch in length replace lifting leg.

NOTE

Repair of lifting legs is accomplished at direct support (DS) maintenance level only, in accordance with the Maintenance Allocation Chart (MAC), Appendix B.

b. Repair. (figure 2-17 and 2-18)

- (1) Remove stitching 3 inches above and below cut or abrasion (A, figure 2-17).
- (2) Cut a 6-inch length of nylon webbing (1).
- (3) Fold and insert webbing in between lifting leg (2) (B, figure 2-17).'
- (4) Using a heavy duty sewing machine and size 6 nylon thread stitch the four layers of webbing with a four point W-W stitch (figure 2-18).

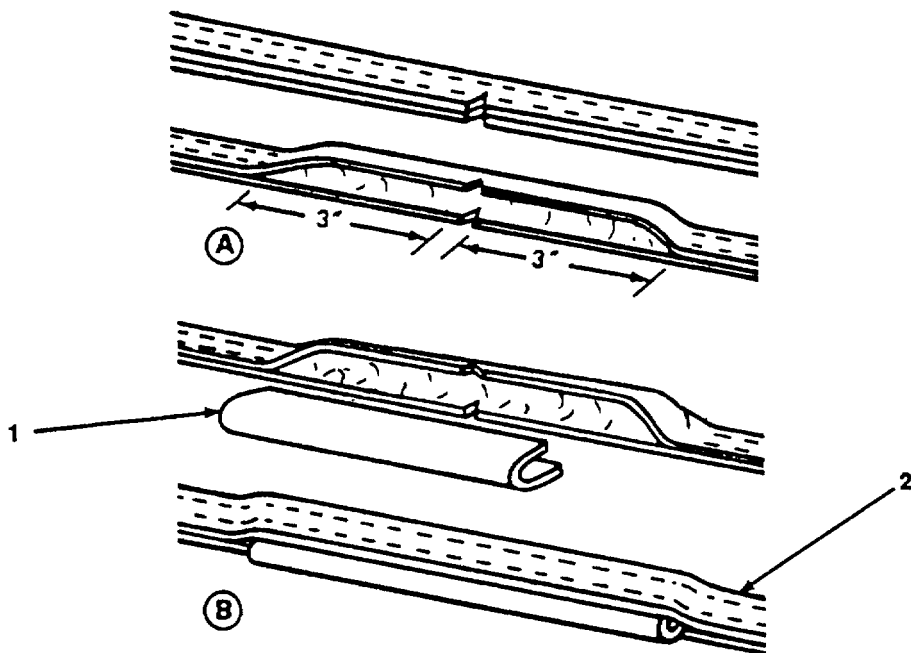

4888-013

Figure 2-17. Splicing Lifting Leg.

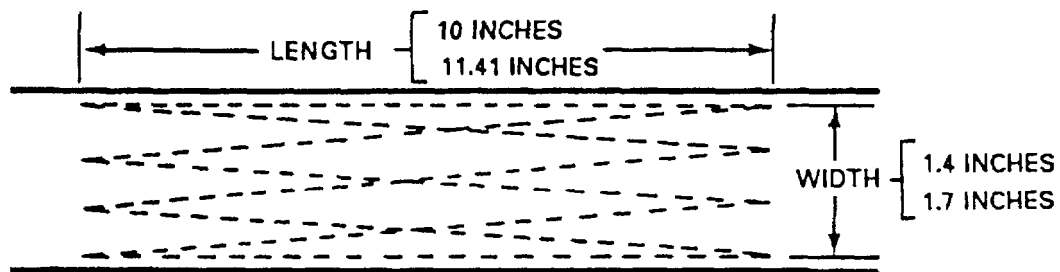

4888-014

Figure 2-18. Lifting Leg Stitch Pattern.

2-29. Lifting Leg (cont.).

c. Replace. (figure 2-19 and 2-20)

- (1) Remove the stitching attaching the lifting legs (1) to the border cord (2) (figure 2-19)
- (2) Cut two 246-inch lengths of nylon webbing and sear end.
- (3) Wrap webbing length around border cord and using a heavy duty sewing machine and size 6 nylon thread, sew hook keeper In original position (figure 2-20).

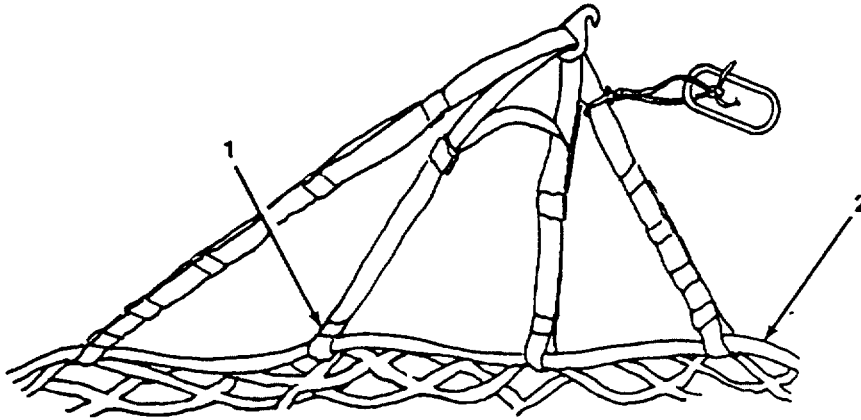

Figure 2-19. Replacing Lifting Legs.

4888-015

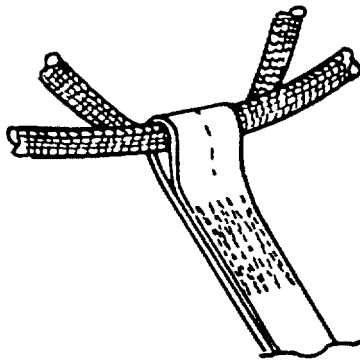

Figure 2-20. Lifting Leg Replacement Details

4888-016

FOLLOW-ON MAINTENANCE-
Install hook keeper strap (para 2-31).

2-30. Buffer.

This task covers:	a. Inspect	b. Repair	c. Replace
-------------------	------------	-----------	------------

Tools:

Knife, item 3, Appendix B
 Knife, Hot Metal, item 4, Appendix B
 Shears, item 9, Appendix B
 Sewing Machine, Heavy Duty, item 12, Appendix B
 Yardstick, item 15, Appendix B

Equipment Condition:

Laid out on work table.

Materials/Parts:

Webbing, Cotton, item 19, Appendix D
 Thread, Nylon, Size 3, item 14/15, Appendix D

- a. Inspect. Refer to paragraph 2-8 for inspection procedures.

NOTE

Repair of buffer is accomplished at direct support (DS) maintenance level only, in accordance with the Maintenance Allocation Chart (MAC), Appendix B.

- b. Repair. Repair buffer by restitching using heavy duty sewing machine and size 3 thread. Stitch over original pattern. Lock each row ½ Inch at each end.

- c. Replace. (figure 2-21).

- (1) Remove buffer (1) by cutting stitching.
- (2) Cut a 15-inch and 16-inch lengths of cotton webbing.
- (3) Position the 15-inch webbing on the Inside and the 16-inch webbing on the outside of lifting legs.
- (4) Using a heavy duty sewing machine and size 3 nylon thread stitch webbing with a 2 inch box stitch and each end.

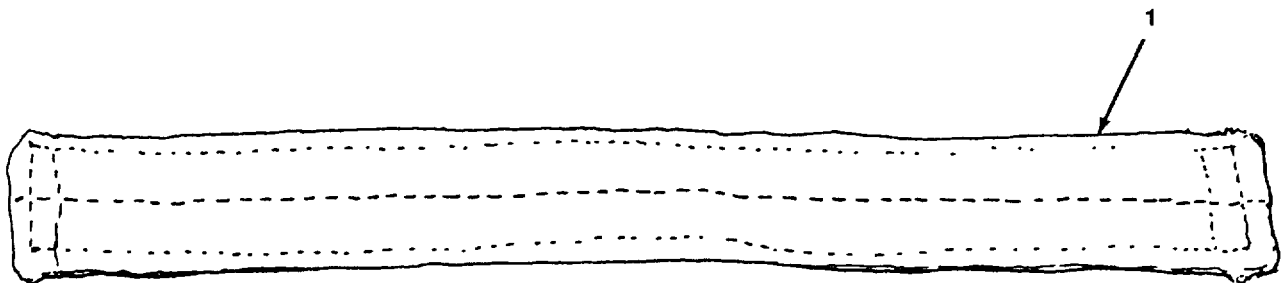

4888-017

Figure 2-21. Buffer Replacement.

2-31. Hook Keeper Strap.

This task covers:	a. Inspect	b. Repair	c. Replace
<i>Tools:</i>		<i>Equipment Condition:</i>	
Knife, item 3, Appendix B Knife, Hot Metal, item 4, Appendix B Shears, item 9, Appendix B Sewing Machine, Heavy Duty, item 12, Appendix B Yardstick, item 15, Appendix B		Laid out on work table.	
<i>Materials/Parts:</i>			
Webbing, Nylon, Type XXVI, item 21, Appendix D Thread, Nylon, Size 6, item 13, Appendix D			

- a. Inspect. Refer to paragraph 2-8 for inspection procedures.

NOTE

Repair of hook keeper strap is accomplished at direct support (DS) maintenance level only, in accordance with the Maintenance Allocation Chart (MAC), Appendix B.

- b. Repair.

Restitching. Restitch keeper strap, using heavy duty sewing machine and size 6, nylon thread. Stitch over original pattern 4 to 6 stitches per inch. Lock each row ½ inch at each end.

- c. Replace. (figure 2-22).

- (1) Remove stitching securing keeper strap (1) to lifting leg (2).
- (2) Cut a 21-inch length of nylon webbing and sear ends.
- (3) Position keeper strap (1) on inside lifting leg (2).

NOTE

Hook keeper strap must be replaced in same position to avoid stress which can pull out stitching and damage the keeper strap.

- (4) Stitch keeper strap (1) in position using single-X-box with two double ends.

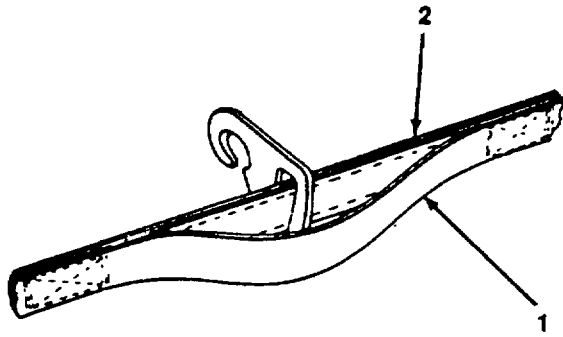

Figure 2-22. Keeper Strap Replacement.
2-37

4888-018

2-32. Net.

This task covers:	a. Inspect	b. Repair
--------------------------	-------------------	------------------

Tools:

Knife, item 3, Appendix B
Shears, item 9, Appendix B
Sewing Machine, Heavy Duty, item 12, Appendix B
Yardstick, item 15, Appendix B
Needle, Splicing, item 16, Appendix B

Equipment Condition:

On work table.

Reference

Cord, Nylon, Type III, item 4, Appendix D
Thread, Nylon, Size 6, item 13, Appendix D

a. *Inspect.* Refer to paragraph 2-8 for inspection procedures.

b. *Repair.*

NOTE

Repair of nets is accomplished at direct support (DS) maintenance level only, in accordance with the Maintenance Allocation Chart (MAC), Appendix B.

(1) *Border cord repair.* (figures 2-23 and 2-24).

- (a) Form a loop on the left side of the damaged area (A, figure 2-23).
- (b) Run the long (free) end of the repair cord under both the starting cord and the border cord, then back through between the two (B, figure 2-23).
- (c) Run the long end of the repair cord through the first loop made to complete the knot (C, figure 2-23).
- (d) Run the long end past the damaged area on the border cord as far as the next mesh connection, then tie the same knot in reverse.
- (e) Secure both end of the repair cord using a heavy duty sewing machine and size 6 nylon thread. (figure 2-24).
- (f) Apply antiabrasion compound and allow to dry 24 hours.

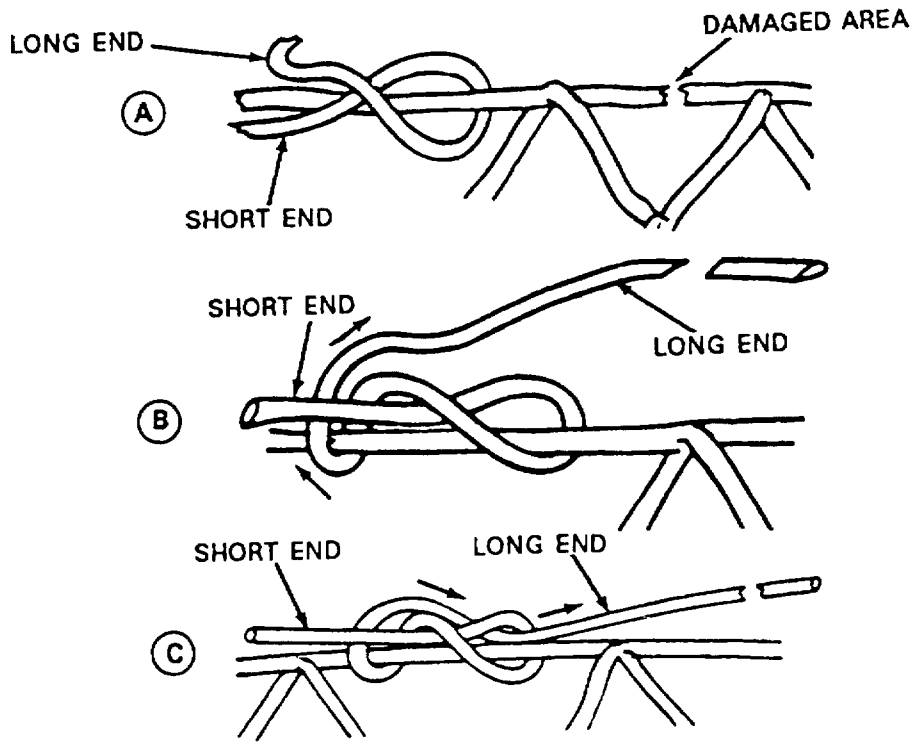

4888-020

Figure 2-23. Border Cord Repair Knot.

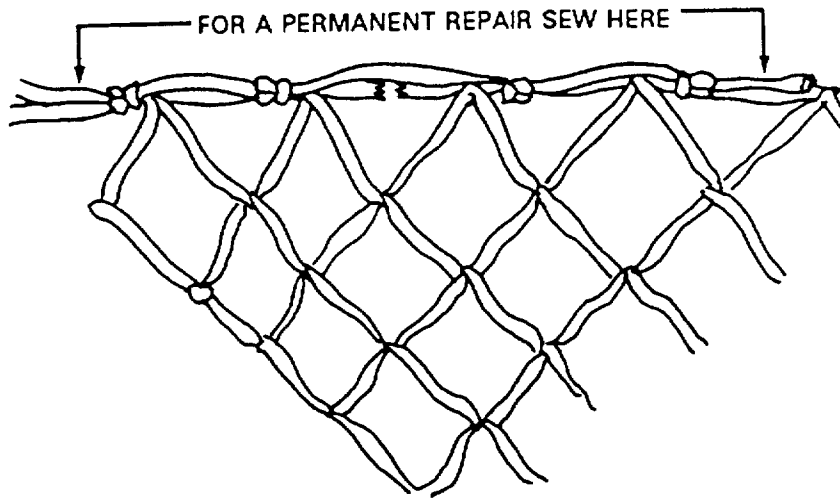

4888-021

Figure 2-24. Border Cord Repair Complete.

2-32. Net (cont).

(2) Center net repair. (figure 2-25).

- (a) Start knotting two intersections away from the broken cord.
- (b) Form a knot at each intersection.
- (c) Secure loose ends by stitching with a heavy duty sewing machine and size 6 nylon thread.

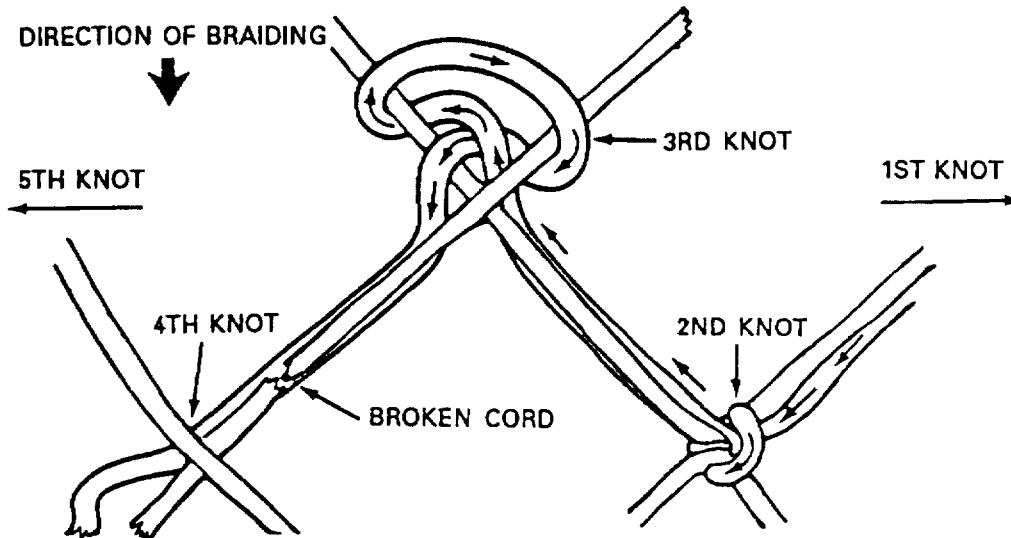

4888-022

Figure 2-25. Center Net Repair.

(3) Major center net repair (figures 2-26 through 2-28).

- (a) Determine the number and length of repair cords needed to repair damage area of the net. Run the repair cord along the damaged net in the same direction the net is intersected (figure 2-26).

NOTE

To repair knot requires at least 9 inches of repair cord.

When repairing Intersections extend repair beyond damage at least 2 intersections.

- (b) Make a 9-inch loop at each knot location.

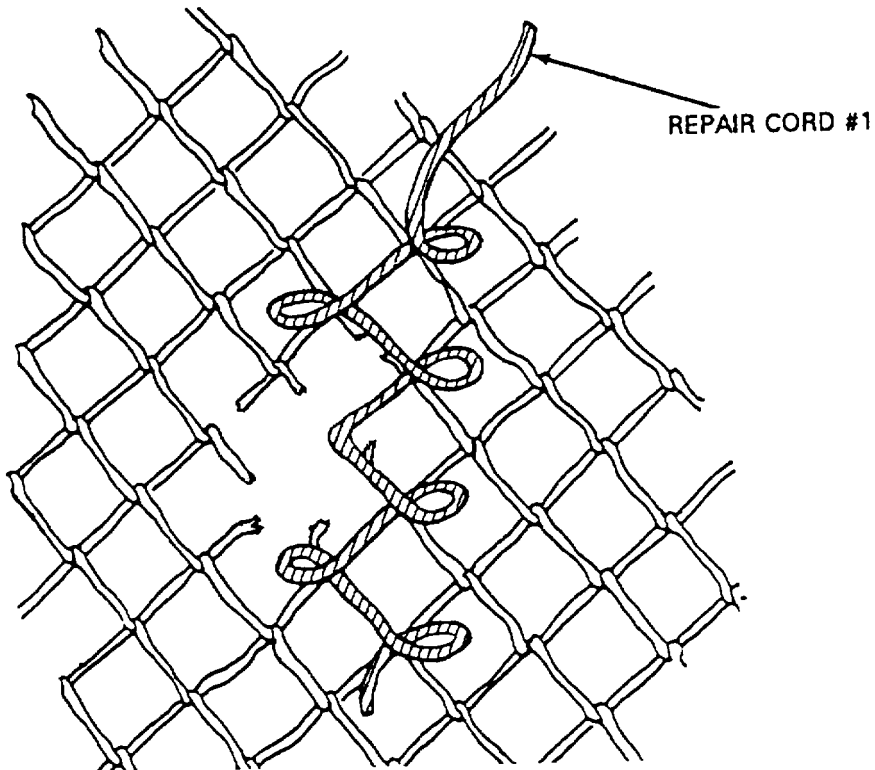

4888-023

Figure 2-26. Repair Cord #1.

- (c) Repeat steps (a) and (b) for remaining repair cords (figure 2-27 and 2-28).
- (d) Tie a single overhand knot above the damaged area at the first good intersection shown by 1 (figure 2-29).
- (e) Follow the direction of the cord to the next knot shown by 2.

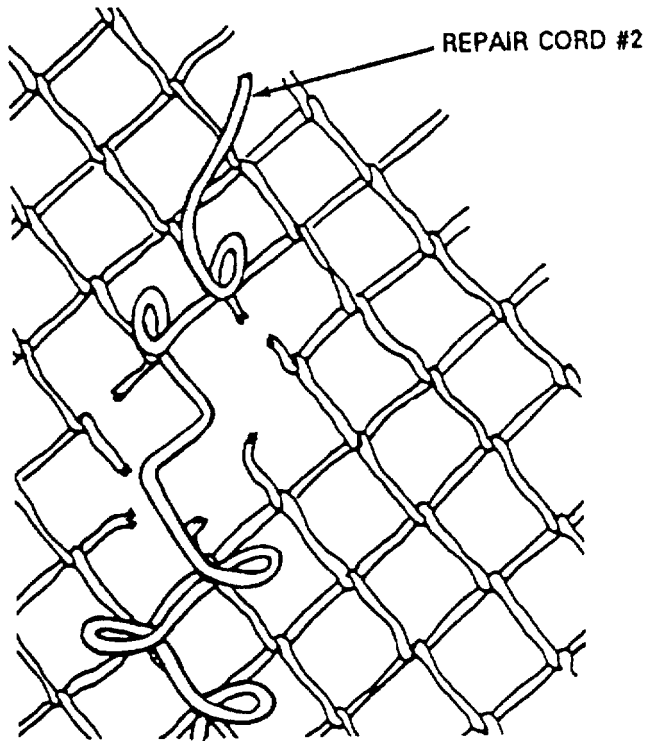

4888-024

Figure 2-27. Repair Cord #2.

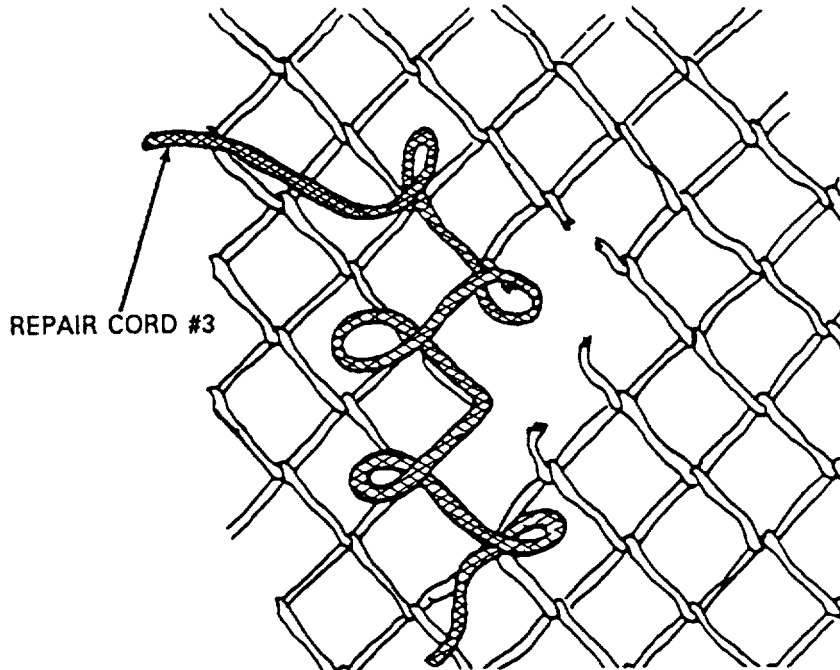

4888-025

Figure 2-28. Repair Cord #3.

NOTE

Leave an elbow for use during next step.

- (f) Tie a knot at the point shown by 3.
- (g) Tie another knot at the point numbered 4.
- (h) Follow the same zig-zag direction of the cord to 5 and tie an overhand knot.
- (i) Go two intersections past the damaged area and tie an overhand knot at 6.

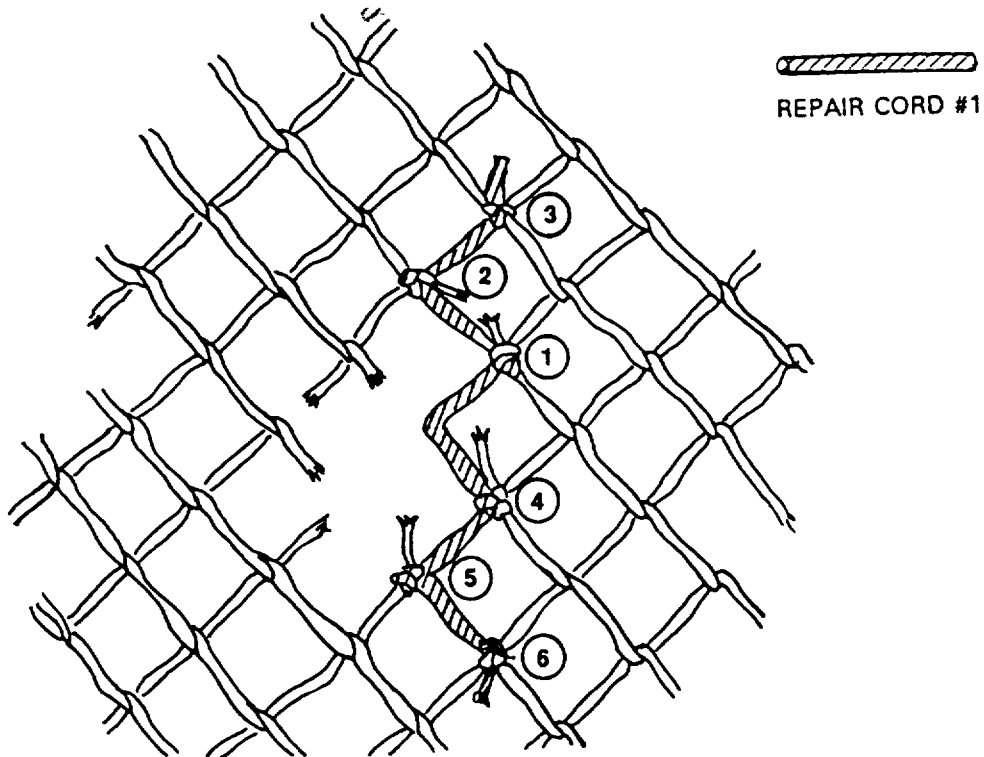

4888-026

Figure 2-29. Repair Cord #1 in Place.

NOTE

The second repair cord starts from the first repair cord.

- (j) Tie an overhand knot at the first undamaged intersection.
- (k) Follow the zig-zag direction of the cord to the next intersection and tie an overhand knot.
- (l) Using spicing needle attach cord #2 at 3 (figure 2-30).
- (m) Leave an elbow at point 4 for next repair cord.

2-32. Net (cont).

(n) Follow the direction of the braiding to point 6 and 7.

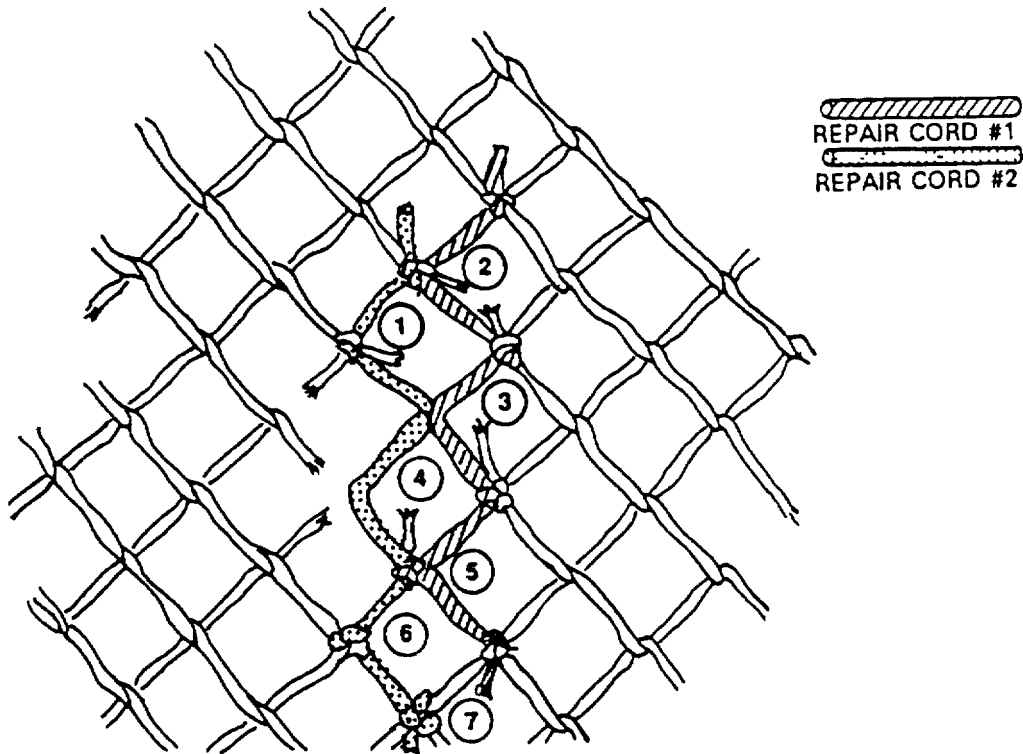

Figure 2-30. Repair Cord #2 in Place.

4888-027

NOTE

Start at the first good Intersection past the damaged area.

- (o) Follow the direction of the braid and tie an overhand knot at point 2 and 3 (figure 2-31).
- (p) Use the splicing needle to attach cord #3 to cord #2 at point 4.
- (q) Tie overhand knots at points 5 and 6.
- (r) Sew the ends of all three repair cords to net using size 6 nylon thread.

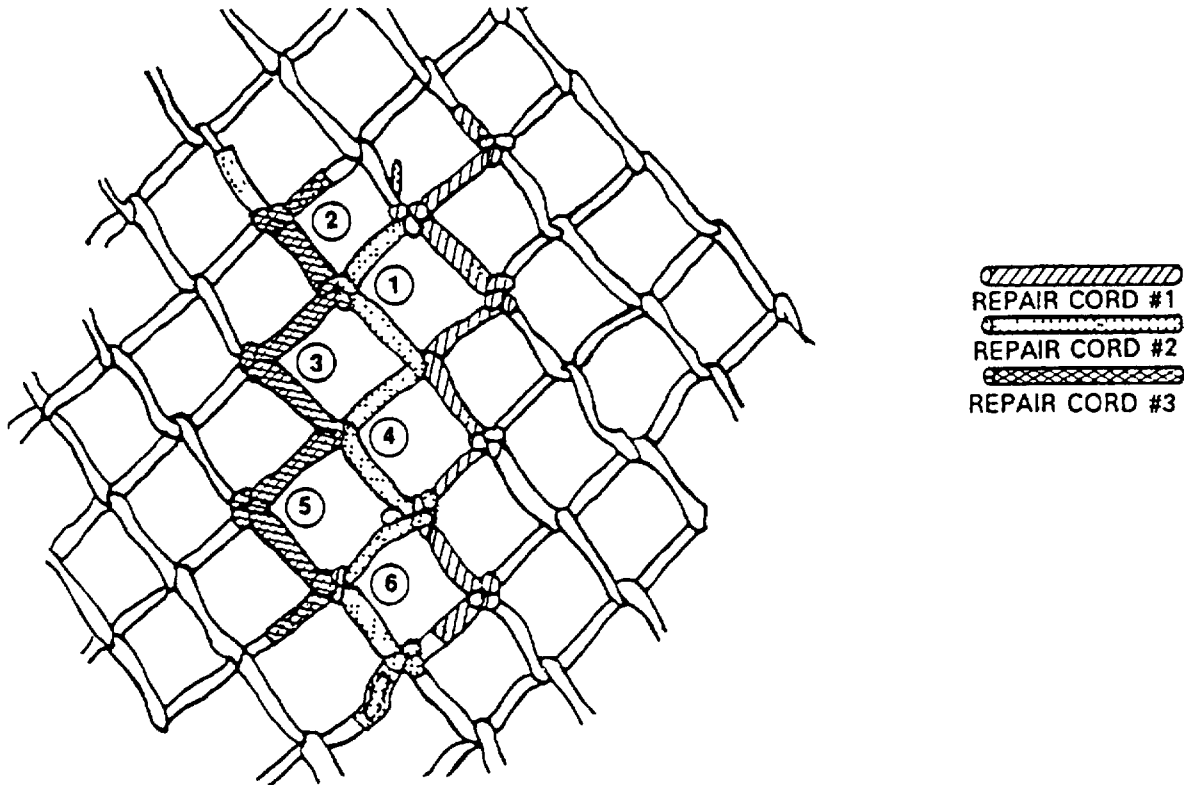

4888-028

Figure 2-31. Net Repair Complete.

2-33. Storage Bag.

This task covers: a. **Inspect** b. **Replace**

Equipment Condition:

Laid out on work table.

- a. Inspect. Inspect storage bag for broken or missing zippers, tears, loose stitching, holes and worn spots.
- b. Replace. Replace an unserviceable/unreparable storage bag with one from stock.

SECTION VII. Preparation for Storage or Shipment

Paragraph		Page
2-34	Storage	2-46
2-35	in-Storage Inspection	2-46
2-36	Shipment	2-47

2-34. Storage.

a. Storage Criteria. Administrative storage of external transport equipment will be accomplished in accordance with AR 750-1 and the instructions furnished below.

b. General Storage Requirements. To insure that serviceability standards of stored external transport equipment are maintained, every effort will be exerted to adhere to the following storage requirements.

- (1) When available, a heated building should be used for storage.
- (2) External transport equipment will be stored in a dry, well-ventilated location and protected from pilferage, dampness, fire dirt, insects, rodents, and direct sunlight.
- (3) External transport equipment will not be stored in a manner which would prevent ventilation or interfere with light fixtures, heating vents, fire fighting devices, cooling units, exits, fire doors.
- (4) External transport items will not be stored in a damaged, dirty, or damp condition.
- (5) All stored external transport items will be marked, segregated, and located for accessibility and easy identification.
- (6) External transport equipment will not be stored in direct contact with any building floor or wall. Storage will be accomplished using bins, shelves, pallets, racks or during to provide airspace between the storage area floor and the equipment. if preconstructed shelving or similar storage accommodations are not available, locally fabricate storage provisions using suitable lumber or wooden boxes.
- (7) All available materials handling equipment should be used as much as possible in the handling of external transport items.
- (8) Periodic rotation of stock, conversion of available space, proper housekeeping policies, and the strict adherence to all regulations will be practiced at all times.

2-35. in-Storage Inspection.

a. General Information. An in-storage inspection is a physical check conducted on a random sample of external transport equipment which is located in storage.

b. Intervals. Cargo nets and slings in storage will be inspected at least semiannually and at more frequent intervals if prescribed by the local maintenance officer.

- c. Inspection. Inspect to insure that the cargo nets and slings are ready for issue.
- (1) Check the cargo nets and slings for proper identification.
 - (2) Check that no damage or deterioration has been incurred.
 - (3) Ensure that all modifications or similar requirements have been completed.
 - (4) Check the adequacy of the storage facilities, efforts taken to control pests and rodents, and protection against unfavorable climatic conditions.

2-36. Shipment.

a. Initial Shipment. The initial packaging and shipping of external transport equipment is the responsibility of item manufacturers who are required to comply with federal and military packaging specifications as stipulated in contractual agreements. External transport equipment is normally shipped to depot activities by domestic freight or parcel post, packaged to comply with overseas shipping requirements. Except for those external transport items which are unpackaged and subject to random Inspections or testing by a depot activity, external transport equipment received by a using unit will be contained in original packaging materials.

b. Shipping Between Maintenance Activities. The shipping of external transport equipment between unit and direct support maintenance activities will be accomplished on a signature verification basis using whatever means of transportation are available. Used equipment and other fabric items will be tagged in accordance with DA PAM 738-751 and rolled, folded, or placed loosely in a storage bag, or other suitable container, as required. Used wood and metal external transport items will be tagged as prescribed in DA PAM 738-751 and placed in suitable type container, if necessary. Unused external transport equipment will be transported in original shipping containers. During shipment, every effort will be made to protect external transport items from weather elements, dust, dirt, oil, grease, and acids. Vehicles used to transport external transport will be inspected to ensure the items are protected from the previously cited material damaging conditions.

APPENDIX A

REFERENCES

A-1. Scope. This appendix lists all forms, technical manuals, and miscellaneous publications referenced in this manual

A-2. Publication Indexes. The following publication indexes should be consulted frequently for the latest changes or revisions of references given in this appendix and for new publications relating to the material covered in this manual:

Consolidated Index of Army Publications and Blank Forms	DA PAM 25-30
The Army Maintenance Management Systems (TAMMS)	DA PAM 738-750
The Army Maintenance Management Systems (Aviation)	DA PAM 738-751

A-3. Technical Manuals.

Preservation, Packaging, Packing of Military Supplies and Equipment (Vols 1 and 2)	TM 38-230-1 and TM 38-230-2
---	--------------------------------

A-4. Field Manuals.

First Aid for Soldiers	FM 21-11
Army Helicopter External Load Operation	FM 55-450-1

A-5. Army Regulations.

Dictionary of United States Army Terms	AR 310-25
Authorized Abbreviation and Brevity Codes	AR 310-50
Packaging of Material	AR 700-15
Army Materiel Maintenance Concepts and Policies	AR 750-1

A-6. Technical Bulletins.

Maintenance Expenditure Limits for FSC Group 16	TB 43-0002-43
---	---------------

A-7. Forms.

Packing Improvement Report	SF Form 364
Product Quality Deficiency Report	SF 368
Equipment Inspection and Maintenance Worksheet	DD Form 2404

APPENDIX B

MAINTENANCE ALLOCATION CHART

SECTION I. INTRODUCTION

B-1. General.

a. This section provides a general explanation of all maintenance and repair functions authorized at various maintenance levels.

b. The Maintenance Allocation Chart (MAC) in Section II designates overall authority and responsibility for the performance of maintenance functions on the identified end item or component. The application of the maintenance functions to the end item or component will be consistent with the capacities and capabilities of the designated maintenance levels.

c. Section III lists the tools and test equipment (both special tools and common tool sets) required for each maintenance function as referenced from Section II.

d. Section IV contains supplemental instructions and explanatory notes for a particular maintenance function.

B-2. Maintenance Functions. Maintenance functions will be limited to and defined as follows:

a. Inspect. To determine the serviceability of an item by comparing its physical, mechanical, and/or electrical characteristics with established standards through examination (e.g. by sight, sound, or feel).

b. Test. To verify serviceability by measuring the mechanical, pneumatic, hydraulic, or electrical characteristics of an item and comparing those characteristics with prescribed standards.

c. Service. Operations required periodically to keep an item in proper operating condition, i.e., clean (includes decontaminate, when required), to preserve, to drain, to paint, or to replenish fuel, lubricants, chemical fluids or gases.

d. Adjust. To maintain or regulate, within prescribed limits, by bringing into proper or exact position, or by setting the operating characteristics to specified parameters.

e. Align. To adjust specified variable elements of an item to bring about optimum or desired performance.

f. Calibrate. To determine and cause corrections to be made or to be adjusted on instruments or test, measuring, and diagnostic equipments used in precision measurement. Consists of comparisons of two instruments, one of which is a certified standard of known accuracy, to detect and adjust any discrepancy in the accuracy of the instrument being compared.

g. Remove/Install. To remove and install the same item when required to perform service or other maintenance functions install may be the act of emplacing, seating or fixing into position a spare, repair part, or module (component or assembly) in a manner to allow the proper functioning of an equipment or system.

h. Replace. To remove an unserviceable item and install a serviceable counterpart in its place "Replace" is authorized by the MAC and is shown as the 3d position code of the SMR code.

i. Repair. The application of maintenance services, including fault location/troubleshooting, removal/installation, and disassembly/assembly procedures, and maintenance actions to identify trouble and restore serviceability to an item by correcting specific damage, fault, malfunction, or failure in a part, subassembly, module (component or assembly), end item, or system.

j. Overhaul. That maintenance effort (service/action) prescribed to restore an item to a completely serviceable/operational condition as required by maintenance standards in appropriate technical publications (i.e., DMWR). Overhaul is normally the highest degree of maintenance performed by the Army. Overhaul does not normally return an item to like new condition.

k. Rebuild. Consists of those services/actions necessary for the restoration of unserviceable equipment to like new condition in accordance with original manufacturing standards. Rebuild is the highest degree of materiel maintenance applied to Army equipment. The rebuild operation includes the act of returning to zero those age measurements (hours/miles, etc) considered in classifying Army equipment/components.

B-3. Explanation of Columns in the MAC, Section II.

a. Column 1. Group Number. Column 1 lists functional group code numbers the purpose of which is to identify maintenance significant components, assemblies, subassemblies, and modules with the next higher assembly. End item group shall be "00".

b. Column 2. Component/Assembly. Column 2 contains the names of components, assemblies, subassemblies, and modules for which maintenance is authorized.

c. Column 3. Maintenance/Function. Column 3 lists the functions to be performed on the item listed in Column 2 (For detailed explanation of these functions, see paragraph B-2).

d. Column 4. Maintenance Level. Column 4 specifies, by the listing of work time figure in the appropriate subcolumn(s), the level of maintenance authorized to perform the function listed in Column 3. This figure represents the active time required to perform the function listed in indicated level of maintenance if the number or complexity of the tasks within the listed maintenance function vary at different maintenance levels, appropriate work time figures will be shown, for each level. The work time figure represents the average time required to restore an item (assembly, subassembly, component, module and item, or system) to a serviceable condition under typical field operating conditions. This time includes preparation time (including any necessary disassembly/assembly time), troubleshooting/fault location time, and quality assurance/quality control time in addition to the time required to perform the specific tasks identified for the maintenance functions authorized in the maintenance allocation chart. The symbol designations for the various maintenance levels are as follows:

- C - Operator or crew
- O - Unit Maintenance
- F - Intermediate Direct Support Maintenance
- H - Intermediate General Support Maintenance
- L - Specialized Repair Activity (SRA)
- D - Depot Maintenance

e. Column 5. Tools and Equipment. Column 5 specifies by code, those common tools sets (not individual tools) and special tools, TMDE, and support equipment required to perform the designated function.

f. Column 5. Remarks. This column shall, when applicable contain a letter code, in alphabetic order, which shall be keyed to the remarks contained in Section IV.

B-4. Explanation of Columns in Tool and Test Equipment Requirements, Section III.

a. Column 1. Reference Code. The tool and test equipment reference code correlates with a code used in the MAC, Section II, Column 5.

b. Column 2. Maintenance Category. The lowest category of maintenance authorized to use the tool or test equipment.

c. Column 3. Nomenclature. Name or Identification of the tool or test equipment.

d. Column 4. National Stock Number. The National stock number of the tool or test equipment.

e. Column 5. Tool Number. The manufacturer's part number.

B-5. Explanation of Columns in Remarks, Section IV.

a. Column 1. Reference Code. The code recorded in column 6, Section II.

b. Column 2. Remarks. This column lists Information pertinent to the maintenance function being performed as indicated in the MAC, Section II.

**SECTION II. MAINTENANCE ALLOCATION CHART FOR 10,000 and 25,000 LB
EXTERIOR TRANSPORT SLING ASSEMBLY**

(1) Group number	(2) Component/ assembly	(3) Maintenance function	(4) Maintenance level					(5) Tools and eqpt.	(6) Remarks
			Unit		Intermediate		Depot		
			C	O	F	H	D		
01	Apex Fitting Assembly	Inspect		0.1				A	
		Service		0.1					
		Repair		0.1					
		Replace		0.1					
	Spacer, Apex	Inspect		0.1					
		Repair		0.1					
		Replace		0.1					
	Pin, Apex	Inspect		0.1					
		Repair		0.1					
		Replace		0.1					
Bolt	Inspect		0.1						
	Replace		0.1						
Nut	Inspect		0.1						
	Replace		0.1						
	Cotter Pin	Replace		0.1					
02	Sling Leg	Inspect		0.1					
		Replace		0.1					
03	Grabhook Assembly	Inspect		0.1					
		Repair		0.2					
		Replace		0.1					
	Keeper	Inspect		0.1					
		Repair		0.1					
		Replace		0.1					
	Keeper Bolt	Inspect		0.1					
		Replace		0.3					
	Spacer	Inspect		0.1					
		Replace		0.1					
Snap Ring	Inspect		0.1						
	Replace		0.1						

**MAINTENANCE ALLOCATION CHART FOR 10,000 and 25,000 LB
EXTERIOR TRANSPORT SLING ASSEMBLY (cont)**

(1) Group Number	(2) Component/ Assembly	(3) Maintenance Function	(4) Maintenance Level					(5) Tools And Equipment	(6) Remarks
			Unit		Inter Mediate		Depot		
			C	O	F	H	D		
04	Link Coupler	Inspect		0.1					
		Replace		0.2					
04	Chain	Inspect		0.1					
		Repair		0.1					
		Replace		0.1					
05	Bag, Storage	Inspect		0.1					
		Replace		0.1					

**MAINTENANCE ALLOCATION CHART FOR 5,000 AND 10,000 LB
EXTERIOR TRANSPORT CARGO NETS**

(1) Group Number	(2) Component/ Assembly	(3) Maintenance Function	(4) Maintenance Level					(5) Tools And Equipment	(6) Remarks
			Unit		Inter Mediate		Depot		
			C	O	F	H	D		
01	Apex Fitting	Inspect		0.1					
		Repair		0.1					
		Replace		0.1					
02	Hook	Inspect		0.1					
		Repair		0.1					
		Replace		0.5					
03	Lifting Leg	Inspect		0.1					
		Repair			0.3				
		Replace			1.7				
	Buffer	Inspect		0.1					
		Repair			0.1				
		Replace			0.3				
	Keeper	Inspect		0.1					
		Repair			0.1				
		Replace			0.3				
04	Net	Inspect		0.1					
		Repair			0.2				
05	Bag, Storage	Inspect		0.1				B	
		Replace		0.1					

SECTION III. TOOL AND TEST EQUIPMENT REQUIREMENTS

Tool or test equipment ref code (1)	Maintenance category (2)	Nomenclature (3)	National NATO stock number (4)	PN Tool number (5)
1	0	Brush, Paint, 1 in	0020-00-721-9640	H-B-451
2	0	File, Flat	5110-00-249-2848	GGG-F-325
3	0	Knife	5110-00-126-2205	MIL-K-818C
4	0	Knife, Hot Metal	3439-01-197-7656	4025
5	0	Needle, Tacking	8315-00-262-3733	FF-N-180
6	0	Pliers, Snap		
7	0	Pot, Melting, Electric	5120-00-242-1276	WG441
8	0	Punch		
9	0	Shears	5110-00-223-6370	GGG-S-278
10	0	Sewing Machine, Light Duty	See Table 2-2	
11	0	Sewing Machine, Zig-Zag	See Table 2-2	
12	0	Sewing Machine, Heavy-duty	See Table 2-2	
13	0	Sewing Machine, Medium Duty	See Table 2-2	
14	0	Screwdriver, Flat Tip	5120-00-293-0314	GGG-S-121
15	0	Yardstick	5120-00-985-6610	GGG-Y-0035
16	0	Splicing Aid	See Appendix E	
17	0	Hammer		

SECTION IV. REMARKS

Reference Code	Remarks/Notes
A	Service Is to clean the equipment.
B	Repair by darning, spice edge binding and repairing grommets. Replacement of parts authorized for unit maintenance (Storage Bag).

**APPENDIX C
REPAIR PARTS AND SPECIAL TOOLS LIST**

SECTION I. INTRODUCTION

C-1. SCOPE. This RPSTL lists and authorizes spares and repair parts; special tools; special test, measurement, and diagnostic equipment (TMDE); and other special support equipment required for performance of unit, direct support and general support maintenance of the Air Conditioner. It authorizes the requisitioning, issue, and disposition of spares, repair parts and special tools as indicated by the source, maintenance and recoverability (SMR) codes.

C-2. GENERAL. In addition to this section, Introduction, this Repair Parts and Special Tools List is divided into the following sections:

a. Section II. Repair Parts List. A list of spares and repair parts authorized by this RPSTL for use in the performance of maintenance. This list also includes parts which must be removed for replacement of the authorized parts. Parts lists are composed of functional groups in ascending alphanumeric sequence, with the parts in each group listed in ascending figure and item number sequence. Bulk materials are listed in item name sequence. Repair parts kits are listed separately in functional groups in Section II. Repair parts for repairable special tools are also listed in this section. Items listed are shown in the associated illustration(s)/figure(s).

b. Section III. Special Tools List. A list of special tools, special TMDE, and other special support equipment authorized by this RPSTL (as indicated by Basis of Issue (BOI) information in DESCRIPTION AND USABLE ON CODE column) for the performance of maintenance.

c. Section IV. Cross-Reference Indexes. A list, in National Item Identification Number (NIIN) sequence, of all national stock numbered items appearing in the listing, followed by a list in alphanumeric sequence of all part numbers appearing in the listings. National stock numbers and part numbers are cross referenced to each illustration figure and item number appearance. The figure and item number index lists figure and item numbers in alphanumeric sequence and cross references NSN, CAGEC and part number.

C-3. EXPLANATION OF COLUMNS (SECTION II)

a. ITEM NO. (Column (1)). Indicates the number used to identify items called out in the illustration.

b. SMR Code (Column (2)). The Source, Maintenance, and Recoverability (SMR) code is a 5-position code containing supply/requisitioning information, maintenance category authorization criteria, and disposition instruction, as shown in the following breakout:

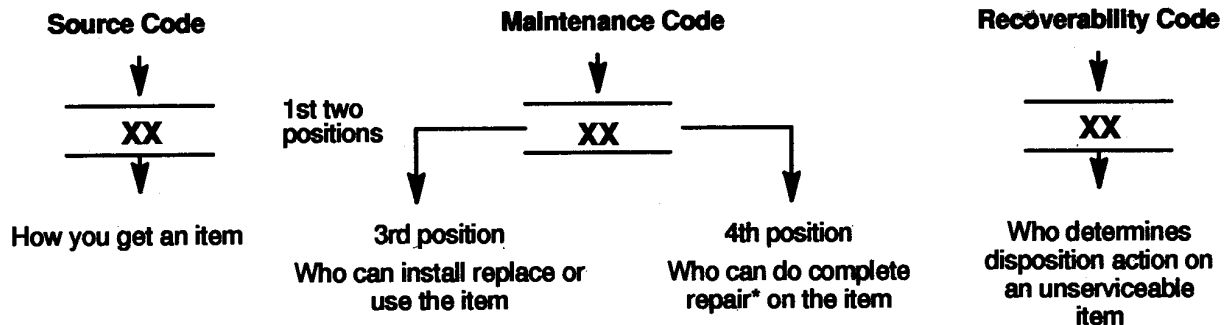

(1) *Source Code.* The source code tells you how you get an item needed for maintenance, repair, or overhaul of an end item/equipment. Source codes are always the first two positions of the SMR code. Explanations of source codes follow.

Code	Explanation
PA PB PC PD PE PF PG	} Stocked items; use the applicable NSN to request/requisition items with these source codes. They are authorized to the category indicated by the code entered in the 3rd position of the SMR code.
	Explanation
KD KF KB	} Items with these codes are not to be requested/requisitioned individually. They are part of a kit which is authorized to the maintenance category indicated in the 3rd position of the SMR code. The complete kit must be requisitioned and applied.

Code	Explanation
MO (Made at org AVUM level) MF (Made at DS/AVUM level) MH (Made at GS level) ML (Made at Specialized Repair Activity (SRA)) MD (Made at Depot)	} Items with these codes are not to be requested/requisitioned individually. They must be made from bulk material which is identified by the part number in the DESCRIPTION and USABLE ON CODE (UOC) column and listed in the Bulk Material group of the repair parts list in the RPSTL. If the item is authorized to you by the 3rd position code of the SMR code, but the source code indicates it is made at a higher level, order the item from the higher level of maintenance.

Code	Explanation
AO (Assembled by org/AVUM Level) AF (Assembled by DS/AVUM Level) AH (Assembled by GS Category) AL (Assembled by SRA) AD (Assembled by Depot)	} Items with these codes are not to be requested/requisitioned individually. The parts that make up the assembled item must be requisitioned or fabricated and assembled at the level of maintenance indicated by the source code. If the 3rd position code of the SMR code, authorizes you to replace the item, but the source code indicates the items are assembled at a higher level, order the item from the higher level of maintenance.

Code	Explanation
XA--	Do not requisition an "XA"-coded item. Order its next higher assembly. (Also, refer to the NOTE below.)
XB--	If an "XB" item is not available from salvage, order it using the CAGE Code and part number given.
XC--	Installation drawing, diagram, instruction sheet, field service drawing, that is identified by manufacturer's part number.
XD--	Item is not stocked. Order an "XD"-coded item through normal supply channels using the CAGE Code and part number given, if no NSN is available.

NOTE

Cannibalization or controlled exchange, when authorized, may be used as a source of supply for items with the above source codes, except for those source coded "XA" or those aircraft support items restricted by requirements of AR 750-1

(2) *Maintenance Code.* Maintenance codes tell you the level(s) of maintenance authorized to USE and REPAIR support items. The maintenance codes are entered in the third and fourth positions of the SMR code as follows:

- (a) The maintenance code entered in the third position tells you the lowest maintenance level authorized to remove, replace, and use an item. The maintenance code entered in the third position will indicate authorization to the following levels of maintenance.

Code	Application/Explanation
C -	Crew or operator maintenance done within unit/AVUM maintenance.
O -	Unit level VAVUM maintenance can remove, replace, and use the item.
F -	Direct support/AVIM maintenance can remove, replace, and use the item.
H -	General support maintenance can remove, replace, and use the item.
L -	Specialized repair activity can remove, replace, and use the item.
D -	Depot can remove, replace, and use the item.

- (b) The maintenance code entered in the fourth position tells whether or not the item is to be repaired and identifies the lowest maintenance level with the capability to do complete repair (i.e., perform all authorized repair functions). (NOTE Some limited repair may be done on an item at a lower level of maintenance, if authorized by the Maintenance Allocation Chart (MAC) and SMR codes). This position will contain one of the following maintenance codes.

Code	Application/Explanation
O --	Unit VAVUM is the lowest level that can do complete repair of the item.
F --	Direct support VAVIM is the lowest level that can do complete repair of the item.
H --	General Support is the lowest level that can do complete repair of the item.
L --	Specialized repair activity is the lowest level that can do complete repair of the item.
D --	Depot is the lowest level that can do complete repair of the item.
Z --	Nonreparable. No repair is authorized.
B --	No repair is authorized. No parts or special tools are authorized for the maintenance of a "B" coded item. However, the item may be reconditioned by adjusting, lubricating, etc., at the user level.

(3) Recoverability code. Recoverability codes are assigned to items to indicate the disposition action on unserviceable items. The recoverability code is entered in the fifth position of the SMR Code as follows:

Recoverability Codes	Application/Explanation
Z --	Nonreparable item. When unserviceable, condemn and dispose of the item at the level of maintenance shown in 3rd position of SMR Code.
O --	Reparable item. When not economically repairable, condemn and dispose of the item at unit or AVUM level.
F --	Reparable item. When uneconomically repairable, condemn and dispose of the item at the direct support or AVIM level.
H --	Reparable item. When uneconomically repairable, condemn and dispose of the item at the general support level.
D --	Reparable item. When beyond lower level repair capability, return to depot. Condemnation and disposal of item not authorized below depot level.
L --	Reparable item. Condemnation and disposal not authorized below specialized repair activity (SRA).
A --	Item requires special handling or condemnation procedures because of specific reasons (e.g., precious metal content, high dollar value, critical material, or hazardous material). Refer to appropriate manuals/directives for specific instructions.

c. FSCM (Column 3). The Federal Supply Code for Manufacturer (FSCM) is a 5-digit numeric code which is used to identify the manufacturer, distributor, or Government agency, etc, that supplies the item

d. Part Number (Column (4)). Indicates the primary number used by the manufacturer (individual, company, firm, corporation, or Government activity), which controls the design and characteristics of the Item by means of its engineering drawings, specifications, standards, and Inspection requirements to Identify an item or range of items.

NOTE

When you use a NSN to requisition an Item, the item you receive may have a different part number from the part ordered.

e. Description and Usable on Code (UOC) (Column (5)). This column includes the following information.

- (1) The Federal Item name and, when required, a minimum description to Identify the Item.
- (2) The physical security classification of the item is indicated by the parenthetical entry, insert applicable physical security classification abbreviation (e g., Phy Sec C1 (C) Confidential, Phy Sec C1 (S) Secret, Phy Sec C1 (T) - Top Secret).
- (3) Items that are included in kits and sets are listed below the name of the kit or set.
- (4) Spare/repair parts that make up an assembled Item are listed immediately following the assembled Item line entry.
- (5) Part numbers for bulk materials are referenced in this column in the line Item entry for the Item to be manufactured/fabricated.
- (6) When the item is not used with all serial numbers of the same model, the effective serial numbers are shown on the last line(s) of the description (before UOC).
- (7) The usable on code, when applicable (see paragraph 5, Special Information).
- (8) In the Special Tools List section, the basis of issue (BOI) appears as the last line(s). In the entry for each special tool, special TMDE, and other special support equipment When density of equipments supported exceeds density spread Indicated in the basis of issue, the total authorization Is increased proportionately
- (9) The statement "End of Figure" appears just below the last Item description In Column 5 for a given figure In Section II.

f. Qty (Column (6)). The Qty (quantity per figure) column indicates the quantity of the Item used in the breakout shown on the Illustration figure, which is prepared for a functional group, subfunctional group, or an assembly A "V" appearing In the column In lieu of a quantity Indicates that the quantity is variable and may vary from application to application

C-4. Special Information.

a. The "Usable on Code" title appears in the lower right corner of column (5). Description Usable on codes are shown in the right-hand margin of the description column Identification of the usable on codes used in the RPSTL are:

Code	Used on
EJX	1670-01-027-2902
EKA	1670-01-027-2900
EJZ	1670-01-058-3811
EJY	1670-01-058-3810

b. Bulk materials required to manufacture items are listed in the Bulk Material Group of this manual NSN's for bulk materials are also referenced in the description column of the line item entry for the item to be manufactured/ fabricated. Detailed manufacturing instructions for items source coded to be manufactured or fabricated are found In this manual.

c. Detailed assembly instructions for items source coded to be assembled from component spare/repair parts are found In this manual. Items that make up the assembly are listed immediately following the assembled Item entry.

d. Line item entries for repair parts kits and sets appear as the last entries in the repair parts listing for the figure In which their parts are listed as repair parts.

e. Items which have the word Bulk In the figure number column will have an Index number shown In the Item number column. This Index number is furnished for use as a cross-reference between the National Stock Number/Part Number Index and the bulk material list in Section II.

f. In the repair parts list, some Items are Indented to show that they are a component or components of the item under which they are indented.

C-5. Explanation of Columns (Section IV).

a National Stock Number (NSN) Index.

(1) Stock number column. This column lists the NSN by National Item Identification Number (NIIN) sequence. The NIIN consists of the last nine digits of the NSN (i e,

NSN
5305-01-574-1467
NIIN

When using this column to locate an Item, ignore the first 4 digits of the NSN. However, the complete NSN should be used when ordering Items by stock number.

(2) *Fig. column.* This column lists the number of the figure where the item is Identified/located. The figures are in numerical order in Section II.

(3) *Item column.* The Item number Identifies the Item associated with the figure listed in the adjacent Fig column. This item is also Identified by the NSN listed on the same line.

b. *Part Number Index.* Part numbers In this index are listed by part number In ascending alphanumeric sequence (I e, vertical arrangement of letter and number combination which places the first letter or digit of each group in order A through Z, followed by the numbers 0 through 9 and each following letter or digit In like order)

(1) *FSCM column.* The Federal Supply Code for Manufacturer (FSCM) is a 5-digit numeric code used to Identify the manufacturer, distributor, or Government agency, etc ,that supplies the item

(2) *Part number column.* Indicates the primary number used by the manufacturer (Individual, firm, corporation, or Government activity), which controls the design and characteristics of the item by means of its engineering drawings, specifications, standards, and Inspection requirements to identify an Item or range of Items.

(3) *Stock number column.* This column lists the NSN for the associated part number and manufacturer identified in the part number and FSCM columns to the left.

(4) *Fig column.* This column lists the number of the figure where the item Is identified/located in Section II and III

(5) *Item column.* The item number is that number assigned to the item as it appears in the figure referenced In the adjacent figure number column

C-6. How to Locate Repair Parts.

a. When National Stock Number or Part Number is Not Known.

(1) *First.* Using the table of contents, determine the functional group or subfunctional group to which the Item belongs. This Is necessary since figures are prepared for functional groups and subfunctional groups, and listings are divided Into the same groups

(2) *Second* Find the figure covering the functional group or subfunctional group to which the Item belongs

(3) *Third* Identify the Items on the figure and note the item number

(4) *Fourth* Refer to the Repair Parts List for the figure to find the line entry for the Item number noted on the figure

(5) *Fifth* Refer to the Part Number Index to find the NSN, If assigned

b When National Stock Number or Part Number is Known

(1) *First.* Using the Index of National Stock Numbers and Part Numbers, find the pertinent National Stock Number or Part Number. The NSN index is in National Item Identification Number (NIIN) sequence (see 4 a (1)). The part numbers in the Part Number index are listed in ascending alphanumeric sequence (see 4.b) Both indexes cross-reference you to the illustration figure and item number of the item you are looking for

*The NIIN consists of the last 9 digits of the NSN (i e.,

NSN

5305-01-574-1467
NIIN

(2) *Second.* After finding the figure and item number, verify that the item is the one you're looking for, then locate the item number in the repair parts list for the figure.

C-7. Abbreviations.

Abbreviations	Explanation
EA	Each
FT	Foot/Feet
IN	Inch/Inches
LG	Long
MTG	Mounting
NF	National Fine (Thread)

SECTION II

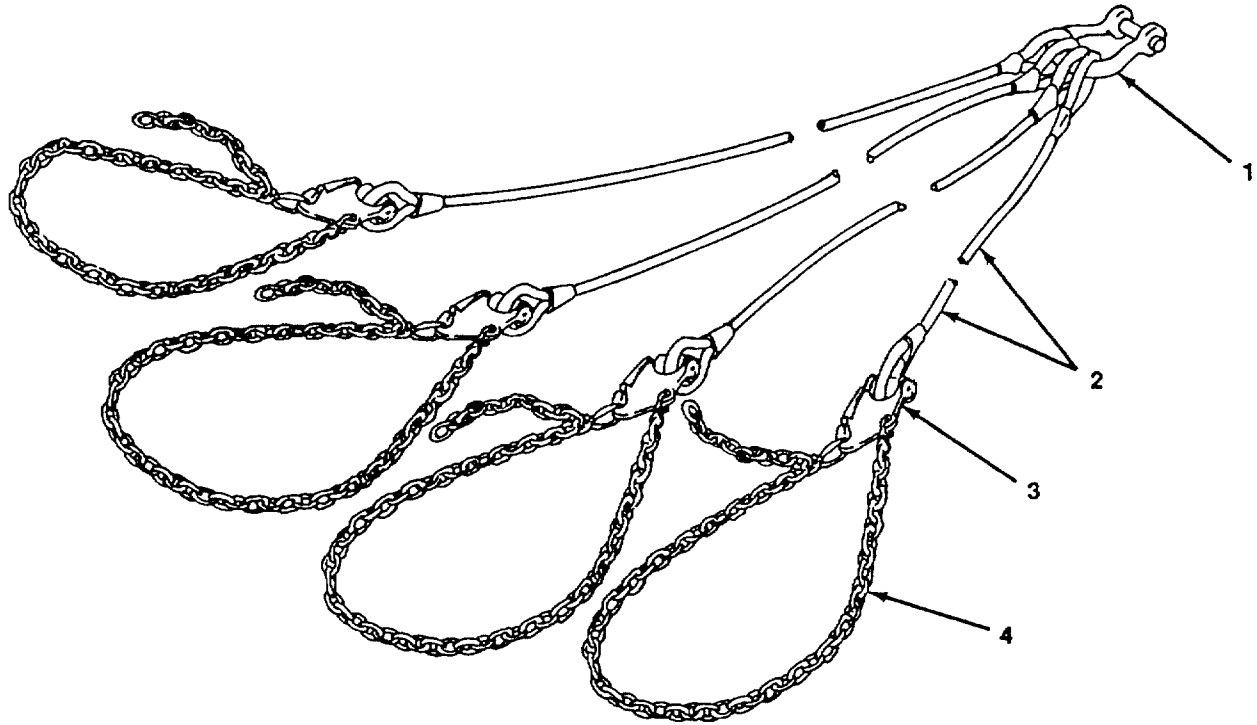

4888-029

Figure C-1. 10,000 and 25,000 lb Sling Assemblies.

(1) ITEM NO	(2) SMR CODE	(3) FSCM	(4) PART NUMBER	(5) DESCRIPTION AND USABLE ON CODES (UOC)	(6) QTY
GROUP 00 SLING ASSEMBLY, 10,000 LB, FIG C-1 10,000 AND 25,000 LB SLING ASSEMBLY.					
1	PAOOO PAOOO	81996 81996	38850-00004-045 38850-00004-046	APEX FITTING ASSEMBLY, UOC. EJX..... APEX FITTING ASSEMBLY, UOC EKA	1
2	PAOZZ PAOZZ	81996 81996	38850-00009-055 38850-00009-056	SLING LEG, UOC EJX SLING LEG, UOC EKA	4
3	PAOOO PAOOO	81996 81996	38850-00011-041 38850-00011-046	GRABHOOK ASSEMBLY, UOC EJX..... GRABHOOK ASSEMBLY, UOC EKA	4
4	PAOOO PAOOO	81996 81996	38850-00053-101 38850-00053-102	CHAIN, WELDED, UOC: EJX..... CHAIN, WELDED, UOC EKA	4
5	PAOZZ	81349	MIL-K-41835	BAG, STORAGE, UOC EJX.....	1
6	PAOZZ	97403	13226E0964-2	CASE, TRANSPORT, UOC EKA.....	1
END OF FIGURE					

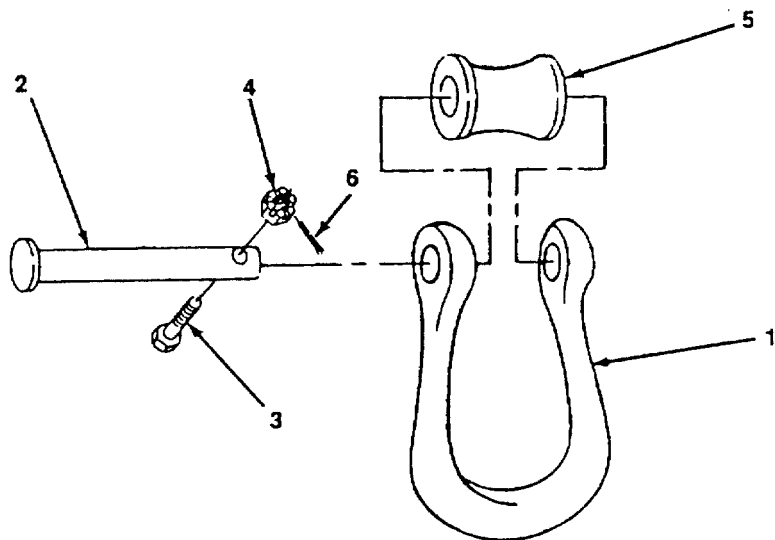

4888-030

Figure C-2. Apex Fitting Assemblies

(1) ITEM NO	(2) SMR CODE	(3) FSCM	(4) PART NUMBER	(5) DESCRIPTION AND USABLE ON CODES (UOC)	(6) QTY
				GROUP 01 APEX FITTING, 10,000 LB, FIG. C-2 APEX FITTING ASSEMBLY	
1	XAOZZ	81996	38850-00006-105	SHACKLE, UOC EJX	1
	XAOZZ	81996	38850-00006-106	SHACKLE, UOC EKA	
2	PAOOO	81996	38850-00008-101	PIN, STRAIGHT, HEAD, UOC EJX	1
	PAOOO	81996	38850-00008-102	PIN, STRAIGHT, HEAD, UOC EKA	
3	PAOZZ	80205	NAS1306-16D	BOLT, SHEAR, UOC: EJX.....	1
	PAOZZ	80205	NAS1306-22D	BOLT, SHEAR, UOC: EKA	
4	PAOZZ	88044	AN320C6	NUT, PLAIN, SLOTTED	1
5	PAOOO	81996	38850-00015-104	SPACER, APEX, FITTING UOC EJX	1
	PAOOO	81996	38850-00015-105	SPACER, APEX, FITTING UOC. EKA	
6	PAOZZ	96906	MS24665-302	PIN, COTTER.....	1
				END OF FIGURE	

SECTION II

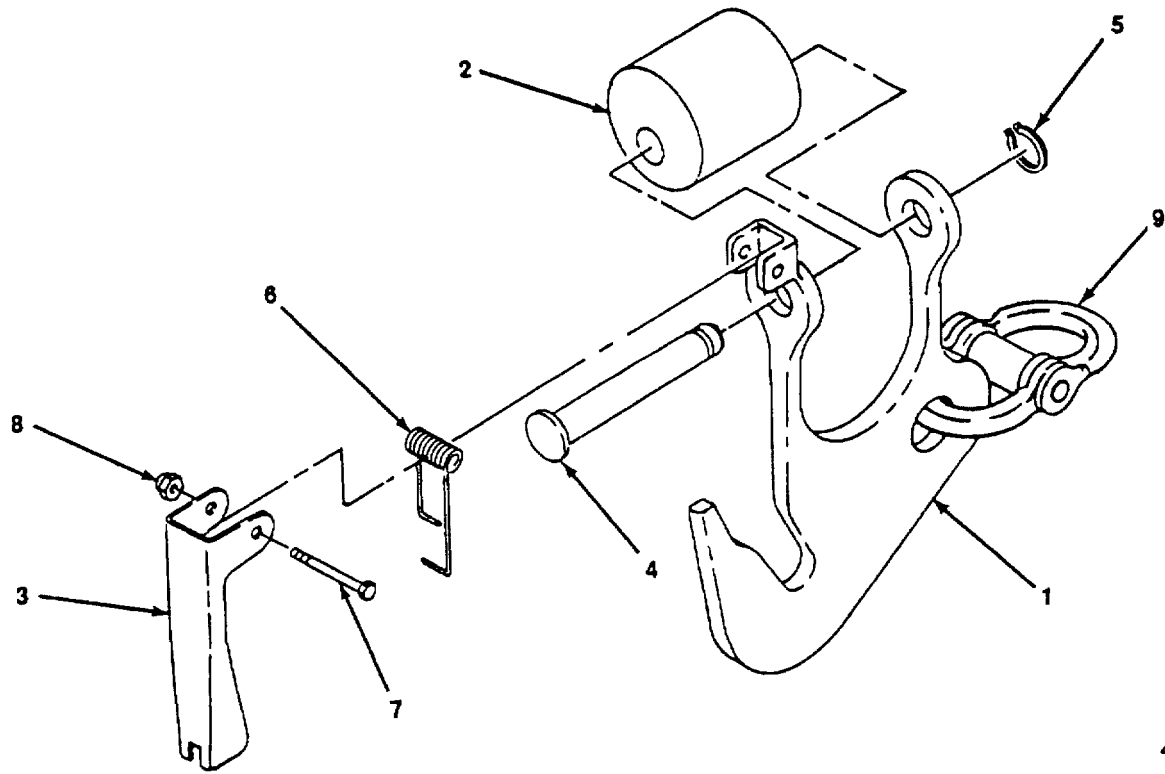

4888-031

Figure C-3. Grabhook Assembly.

(1) ITEM NO	(2) SMR CODE	(3) FSCM	(4) PART NUMBER	(5) DESCRIPTION AND USABLE ON CODES (UOC)	(6) QTY
				GROUP 03 GRABHOOK ASSEMBLY	
				FIG. C-3. GRABHOOK ASSEMBLY	
1	XAOZZ	81996	38850-00013-101	GRABHOOK UOC: EJX	4
	XAOZZ	81996	38850-00013-106	GRABHOOK UOC: EKA	
2	PAOZZ	81996	38850-00015-101	SPACER, SLING, UOC EJX.....	4
	PAOZZ	81996	38850-00015-102	SPACER, SLING, UOC EKA	4
3	PAOZZ	81996	38850-00017-101	KEEPER, GRABHOOK, UOC EJX	4
	PAOZZ	81996	38850-00017-102	KEEPER, GRABHOOK, UOC EKA	
4	PAOZZ	81996	38850-00008-103	PIN, GROVE, HEADED, UOC EJX.....	4
	PAOZZ	81996	38850-00008-104	PIN, GROVE, HEADED, UOC EKA	
5	PAOZZ	96906	MS3217-1050	RING, RETAINING, UOC EJX.....	4
	PAOZZ	96906	MS3217-1075	RING, RETAINING, UOC: EKA	
6	PAOZZ	81996	38850-00019-101	SPRING, HELICAL.....	4
7	PAOZZ	80205	NAS1303-21	BOLT, SHEAR.....	4
8	PAOZZ	96906	MS51865-6C	NUT, SELF-LOCKING	4
9	PAOZZ	80535	577-0615	LINK, COUPLER UOC EJX	4
	PAOZZ	13743	664241	LINK, COUPLER UOC EKA	
				END OF FIGURE	

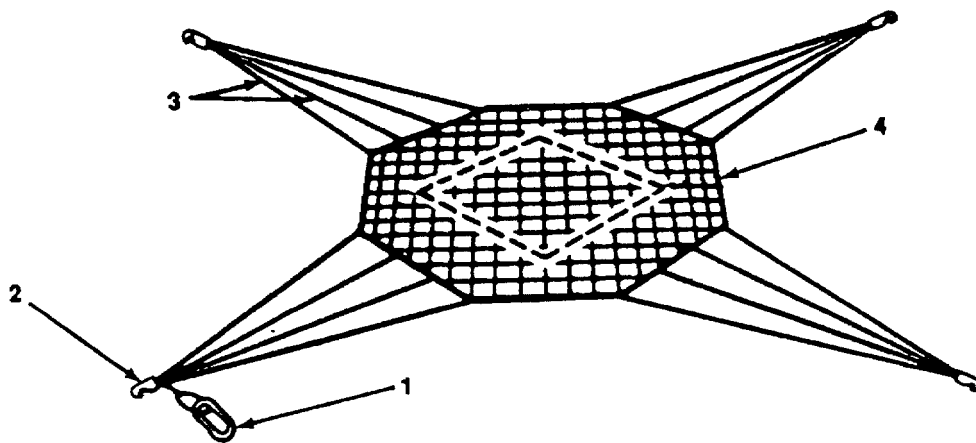

4888-032

Figure C-4. 5,000 and 10,000 lb Cargo Nets.

SECTION II

TM 10-1670-295-23&P

(1) ITEM NO	(2) SMR CODE	(3) FSCM	(4) PART NUMBER	(5) DESCRIPTION AND USABLE ON CODES (UOC)	(6) QTY
				GROUP 00 CARGO NET, 5,000 LB, AND 10,000 LB	
				FIG C-4 5,000 AND 10,000 LB CARGO NET	
1	PAOOO	81996	6019	FITTING, APEX	1
2	PAOOO	81996	6020	HOOK	4
3	MFFFF	81996	6018-25	LIFTING LEG, UOC: EJZ	4
	MFFFF	81996	6018-30	LIFTING LEG, UOC: EJY	
4	XAFFF	81996	6018-15	NET, UOC: EJZ	1
	XAFFF	81996	6018-20	NET, UOC: EJY	
5	PAOZZ	97403	13226E0964-2	STORAGE CASE.....	1
				END OF FIGURE	

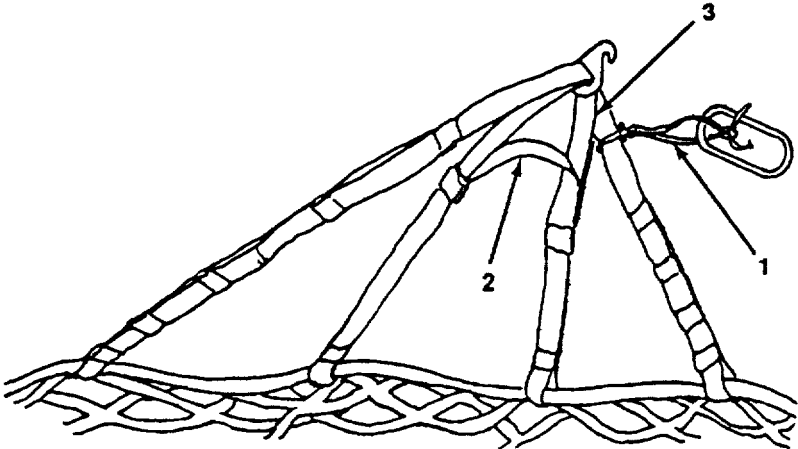

4888-033

Figure C-5. Lifting Legs.

SECTION II

TM 10-1670-295-23&P

(1) ITEM NO	(2) SMR CODE	(3) FSCM	(4) PART NUMBER	(5) DESCRIPTION AND USABLE ON CODES (UOC)	(6) QTY
				GROUP 03 5,000 AND 10,000 LB LIFTING LEG	
				FIG C-5 LIFTING LEG 5,000 AND 10,000 LB	
1	MOOZZ	81996	6018-45	TETHER CORD	1
2	MFFFF	81996	6018-35	KEEPER	4
3	MFFFF	81996	6018-25	BUFFER	4
				END OF FIGURE	

(1) ITEM NO	(2) SMR CODE	(3) FSCM	(4) PART NUMBER	(5) DESCRIPTION AND USABLE ON CODES (UOC)	(6) QTY
				GROUP 99 BULK MATERIALS	
1	PAOZZ	81349	MIL-W-4088, TYPE XXVI	WEBBING, NYLON, OD	YD
2	PAOZZ	81349	MIL-C-5040, TYPE III	CORD, NYLON, OD.....	YD
3	PAOZZ	81349	8305-00-260-2565	WEBBING, COTTON, OD	YD
				END OF FIGURE	

Section III. SPECIAL TOOLS LIST

Not Applicable

CROSS REFERENCE INDEXES

NATIONAL STOCK NUMBER INDEX

STOCK NUMBER	FIG	ITEM	STOCK NUMBER	FIG.	ITEM
1080-00-108-1155	C-1	6	1670-01-058-3811	C-4	-
5310-00-207-9274	C-2	4	4010-01-058-4771	C-1	4
5315-00-234-1864	C-2	6	4010-01-058-4772	C-1	4
5365-00-261-3918	C-3	5	1670-01-067-9989	C-4	2
8460-00-606-8366	C-1	5	1670-01-070-5276	C-4	1
5306-00-771-7621	C-3	7	4030-01-100-1684	C-3	3
5306-00-944-1536	C-2	3	4030-01-100-1685	C-3	3
5306-00-944-2659	C-2	3	1670-01-109-2543	C-3	2
5310-01-024-7080	C-3	8	1670-01-109-2544	C-3	2
1670-01-027-2900	C-1	-	5315-01-115-3482	C-2	2
1670-01-027-2902	C-1	-	5360-01-115-6833	C-3	6
4010-01-041-9751	C-3	9	4020-01-118-5826	C-4	4
5365-01-046-3670	C-3	5	4020-01-119-5994	C-4	4
1670-01-047-6814	C-1	2	5315-01-119-9065	C-2	2
1670-01-047-6815	C-1	2	5315-01-121-0497	C-3	4
4030-01-048-4044	C-1	1	5315-01-121-2874	C-3	4
4030-01-048-4045	C-1	1	4010-01-193-9331	C-3	9
4030-01-048-4046	C-1	3	1670-01-235-0907	C-2	5
4030-01-048-4047	C-1	3	1670-01-235-0908	C-2	5
1670-01-058-3810	C-4				

CROSS REFERENCE INDEXES (cont)

PART NUMBER INDEX

FSCM	PART NUMBER	STOCK NUMBER	FIG.	ITEM
96906	AN 320C6	5310-00-207-9274	C-2	4
81349	MIL-C-5040		BULK	2
81349	MIL-K-41835	8460-00-606-8366	C-1	5
81349	MIL-W-4088		BULK	1
96906	MS24665-302	5315-00-234-1864	C-2	6
96906	MS 3217-1050	5365-01-046-3670	C-3	5
96906	MS 3217-1075	5365-00-261-3918	C-3	5
96906	MS51865-6C	5310-01-024-7080	C-3	8
80205	NAS 1303-21	5306-00-771-7621	C-3	7
80205	NAS 1306-16D	5306-00-944-1536	C-2	3
80205	NAS 1306-22D	5306-00-944-2659	C-2	3
97403	13226E0964-2	1080-00-168-1155	C-1	6
81996	38850-00001-043	1670-01-027-2902	C-1	-
81996	38850-00001-044	1670-01-027-2900	C-1	-
81996	38850-00004-045	4030-01-048-4045	C-1	1
81996	38850-00004-046	4030-01-048-4044	C-1	1
81996	38850-00008-101	5315-01-115-3482	C-2	2
81996	38850-00008-102	5315-01-119-9065	C-2	2
81996	38850-00008-103	5315-01-121-0497	C-3	4
81996	38850-00008-104	5315-01-121-2874	C-3	4
81996	38850-00009-055	1670-01-047-6814	C-1	2
81996	38850-00009-056	1670-01-047-6815	C-1	2
81996	38850-00011-041	4030-01-048-4046	C-1	3
81996	38850-00011-046	4030-01-048-4047	C-1	3
81996	38850-00015-101	1670-01-109-2543	C-3	2
81996	38850-00015-102	1670-01-109-2544	C-3	2
81996	38850-00015-104	1670-01-235-0908	C-2	5
81996	38850-00015-105	1670-01-235-0907	C-2	5
81996	38850-00017-101	4030-01-100-1684	C-3	3
81996	38850-00017-102	4030-01-100-1685	C-3	3
81996	38850-00019-101	5360-01-115-6833	C-3	6
81196	38850-00053-101	4010-01-058-4772	C-1	4
81996	38850-00053-102	4010-01-058-4771	C-1	4
80535	577-0615	4010-01-193-9331	C-3	9
81996	6018-5	1670-01-058-3811	C-4	-
81996	6018-10	1670-01-058-3810	C-4	-
81996	6018-15	4020-01-118-5826	C-4	4
81996	6018-20	4020-01-119-5994	C-4	4
81996	6019	1670-01-070-5276	C-4	1
81996	6020	1670-01-067-9989	C-4	2
13743	664241	4010-01-041-9751	C-3	9
81349	8305-00-260-2565		BULK	3

APPENDIX D

EXPENDABLE/DURABLE SUPPLIES AND MATERIALS LIST

Section I. INTRODUCTION

D-1 Scope. This appendix lists expendable supplies and materials you need to operate and maintain the 10,000 and 25,000 lb External Transport Sling Assembly and 5,000 and 10,000 lb External Transport Cargo Nets. These items are authorized to you by CTA 50-970, Expendable Items (Except Medical, Class V, Repair Parts, and Heraldic Items).

D-2. Explanation of Columns.

a. Column (1) - Item Number. This number is assigned to the entry in the listing and is referenced in the narrative Instructions to identify the material (e g, "Use Cloth, Abrasive Item 5, App D").

b. Column (2) - Level. This column identifies the lowest level of maintenance that requires the listed item (Enter as applicable)

C	-	Operator/Crew
O	-	Organizational Maintenance - Unit Maintenance
F	-	Direct Support Maintenance - Intermediate Maintenance
H	-	General Support Maintenance - Intermediate Maintenance
D	-	Depot Maintenance

c. Column (3) - National Stock Number. This is the National stock number assigned to the item, use It to request or requisition the item.

d. Column (4) - Description. Indicates the Federal item name and, if required, a description to Identify the item.

e. Column (5) - Unit of Measure (U/M). Indicates the measure used in performing the actual maintenance function. This measure is expressed by a two-character alphabetical abbreviation (e g , ea, in, pr). If the unit of measure differs from the unit of issue, requisition the lowest unit of Issue that will satisfy your requirements.

Section II. EXPENDABLE/DURABLE SUPPLIES AND MATERIALS LIST

(1) Item number	(2) Level	(3) National stock number	(4) Description	(5) U/M
1	O	7920-00-282-2470	Brush, Scrub, Household	ea
2	O	8020-00-721-9646	Brush, Paint, 1"	ea
3	O	5350-00-221-0872	Cloth, Abrasive	ea
4	O	4020-00-246-6888	Cord, Nylon, Type III	yd
5	O	8030-01-152-2286	Compound, Anti Abrasion, OD	cn
6	O	8030-01-154-2327	Compound, Anti Abrasion, Black	cn
7	O	4020-01-118-5826	Cord, Nylon, UOC: EJZ	yd
8	O	4020-01-119-5994	Cord, Nylon, UOC: EJY	yd
9	O	7930-00-281-4370	Dishwashing Compound, Hand Flake	50-lb
10	O	9150-00-168-2000	Lubricant, Solid Film	cn
11	O	7920-00-205-3570	Rag, Wiping	bl
12	O	6810-00-270-9982	Tetrachloroethylene, Technical	dr
13	O	8310-00-262-2780	Thread, Nylon Size 6, OD	tu
14	O	8310-00-267-3027	Thread, Nylon, Size 3, OD	tu
15	O	8310-00-248-9714	Thread, Nylon, Size 3, Natural	tu
16	O	8010-00-297-1560	Paint, OD, TT-E-529	tu
17	O	5315-00-234-1864	Pin, Cotter	ea
18	O	9160-00-285-2044	Wax, Paraffin, 1-lb Cake	ea
19	O	8305-00-260-2565	Webbing, Cotton, OD	yd
20		8305-00-261-8585	Webbing, Nylon, Type VIII	yd
21	O	8305-01-206-9219	Webbing, Nylon, Type XXVI, OD	yd

APPENDIX E

ILLUSTRATED LIST OF MANUFACTURED ITEMS

Complete instructions for making items authorized to be manufactured or fabricated are located in Chapter 2, Section VII of this manual. Fabricate a splicing aid in accordance with figure E-1.

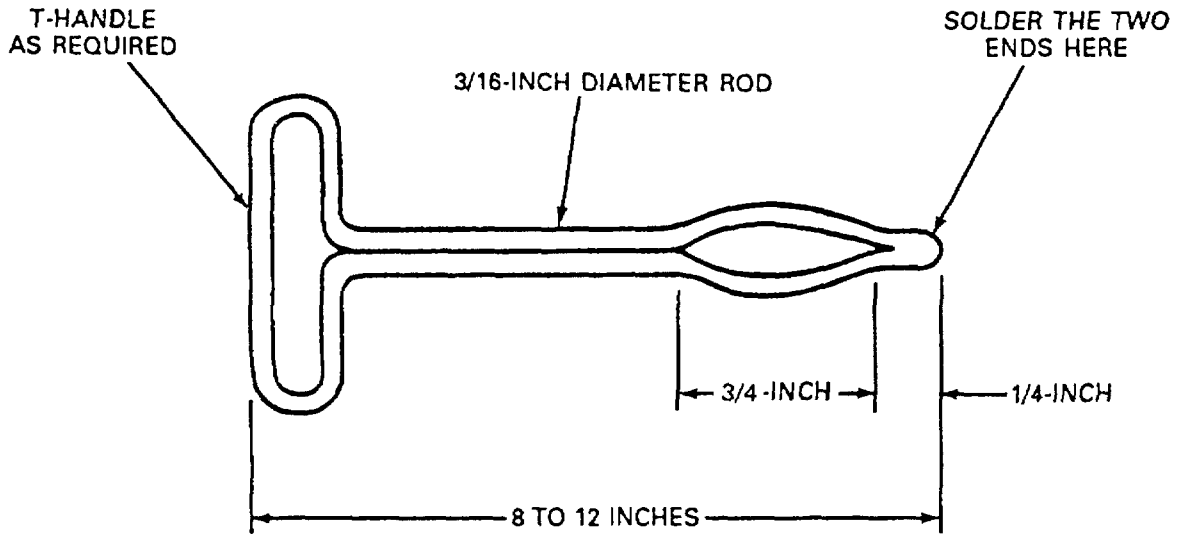

SPLICING AND FABRICATIONS

4888-034

Figure E-1. Splicing Aid Fabrication.

E-1/(E-2 blank)

INDEX

Subject	Paragraph
A	
Apex Fitting	2-12
Apex Pin.....	2-14
Apex Spacer.....	2-13
Appendices	
A- References.....	A-1
B - Maintenance Allocation Chart	B-1
C - Repair Parts and Special Tools List	C-1
D - Expendable/Durable Supplies and Materials List	D-1
E - Illustrated List of Manufactured Items	E-1
B	
Bolt.....	2-15
Buffer	2-30
C	
Chain.....	2-25
Cleaning and Drying	2-11
Common Tools	2-1
Cotter Pin	2-17
Coupler Link	2-24
Cross Reference.....	C-2
D	
Destruction of Army Material to Prevent Enemy Use	1-3
Difference Between Models.....	1-10
E	
Expendable/Durable Supplies and Materials List.....	D-1
External Transport Cargo Net	2-32
External Transport Sling Assembly	2-18
Equipment Characteristics, Capabilities and Features.....	1-6
Equipment Data.....	1-8
Equipment Description and Data	1-7
Equipment Differences	1-10
F	

INDEX (cont)

Subject	Paragraph
G	
Grabhook Assembly	2-19
H	
Hook.....	2-28
Hook Keeper Strap	2-31
I, J	
K	
Keeper.....	2-20
Keeper Bolt.....	2-21
L	
Lifting Leg.....	2-29
Location and Description of Major Components	1-7
M	
Maintenance, Direct Support Unit	2-7
Maintenance Forms and Records	1-2
N	
Net	2-32
Nuts.....	2-16
P	
Painting	2-9
Preparation for Storage and Shipment.....	1-4
Principles of Operation	1-11

INDEX (cont)

Subject Paragraph

R

Repair Parts and Special Tools List	C-1
References.....	A-1
Reporting of Equipment Improvement Recommendation (EIR).....	1-5

S

Safety, Care and Handling.....	1-9
Searing.....	2-10
Service Upon Receipt.....	2-4
Shipment	2-36
Sling Leg	2-18
Snap Ring.....	2-23
Spacer.....	2-22
Storage Criteria	2-34

T

U

Unit Maintenance Functions.....	2-7
Unit Preventive Maintenance Checks and Services (PMCS).....	2-6

V, W, X, Y, Z

By Order of the Secretary of the Army:

CARL E. VUONO
General, United States Army
Chief of Staff

Official:

PATRICIA P. HICKERSON
Colonel, United States Army
The Adjutant General

DISTRIBUTION

To be distributed In accordance with DA Form 12-25E, (Qty rqr blk no 1256)

RECOMMENDED CHANGES TO EQUIPMENT TECHNICAL PUBLICATIONS

 <p style="font-size: small; margin: 0;"><i>THEN...JOT DOWN THE DOPE ABOUT IT ON THIS FORM. CAREFULLY TEAR IT OUT, FOLD IT AND DROP IT IN THE MAIL.</i></p>		SOMETHING WRONG WITH PUBLICATION	
		FROM: (PRINT YOUR UNIT'S COMPLETE ADDRESS)	
PUBLICATION NUMBER		PUBLICATION DATE	
PUBLICATION TITLE		DATE SENT	
IN THIS SPACE, TELL WHAT IS WRONG AND WHAT SHOULD BE DONE ABOUT IT.			
BE EXACT	PIN-POINT WHERE IT IS		
PAGE NO.	PARA-GRAPH	FIGURE NO.	TABLE NO.
PRINTED NAME, GRADE OR TITLE AND TELEPHONE NUMBER		SIGN HERE	

TEAR ALONG PERFORATED LINE

DA FORM 1 JUL 79 **2028-2**

PREVIOUS EDITIONS ARE OBSOLETE.

P.S.--IF YOUR OUTFIT WANTS TO KNOW ABOUT YOUR RECOMMENDATION MAKE A CARBON COPY OF THIS AND GIVE IT TO YOUR HEADQUARTERS.

The Metric System and Equivalents

Linear Measure

1 centimeter = 10 millimeters = .39 inch
 1 decimeter = 10 centimeters = 3.94 inches
 1 meter = 10 decimeters = 39.37 inches
 1 dekameter = 10 meters = 32.8 feet
 1 hectometer = 10 dekameters = 328.08 feet
 1 kilometer = 10 hectometers = 3,280.8 feet

Weights

1 centigram = 10 milligrams = .15 grain
 1 decigram = 10 centigrams = 1.54 grains
 1 gram = 10 decigrams = .035 ounce
 1 dekagram = 10 grams = .35 ounce
 1 hectogram = 10 dekagrams = 3.52 ounces
 1 kilogram = 10 hectograms = 2.2 pounds
 1 quintal = 100 kilograms = 220.46 pounds
 1 metric ton = 10 quintals = 1.1 short tons

Liquid Measure

1 centiliter = 10 milliliters = .34 fl. ounce
 1 deciliter = 10 centiliters = 3.38 fl. ounces
 1 liter = 10 deciliters = 33.81 fl. ounces
 1 dekaliter = 10 liters = 2.64 gallons
 1 hectoliter = 10 dekaliters = 26.42 gallons
 1 kiloliter = 10 hectoliters = 264.18 gallons

Square Measure

1 sq. centimeter = 100 sq. millimeters = .155 sq. inch
 1 sq. decimeter = 100 sq. centimeters = 15.5 sq. inches
 1 sq. meter (centare) = 100 sq. decimeters = 10.76 sq. feet
 1 sq. dekameter (are) = 100 sq. meters = 1,076.4 sq. feet
 1 sq. hectometer (hectare) = 100 sq. dekameters = 2.47 acres
 1 sq. kilometer = 100 sq. hectometers = .386 sq. mile

Cubic Measure

1 cu. centimeter = 1000 cu. millimeters = .06 cu. inch
 1 cu. decimeter = 1000 cu. centimeters = 61.02 cu. inches
 1 cu. meter = 1000 cu. decimeters = 35.31 cu. feet

Approximate Conversion Factors

To change	To	Multiply by	To change	To	Multiply by
inches	centimeters	2.540	ounce-inches	newton-meters	.007062
feet	meters	.305	centimeters	inches	.394
yards	meters	.914	meters	feet	3.280
miles	kilometers	1.609	meters	yards	1.094
square inches	square centimeters	6.451	kilometers	miles	.621
square feet	square meters	.093	square centimeters	square inches	.155
square yards	square meters	.836	square meters	square feet	10.764
square miles	square kilometers	2.590	square meters	square yards	1.196
acres	square hectometers	.405	square kilometers	square miles	.386
cubic feet	cubic meters	.028	square hectometers	acres	2.471
cubic yards	cubic meters	.765	cubic meters	cubic feet	35.315
fluid ounces	milliliters	29.573	cubic meters	cubic yards	1.308
pints	liters	.473	milliliters	fluid ounces	.034
quarts	liters	.946	liters	pints	2.113
gallons	liters	3.785	liters	quarts	1.057
ounces	grams	28.349	liters	gallons	.264
pounds	kilograms	.454	grams	ounces	.035
short tons	metric tons	.907	kilograms	pounds	2.205
pound-feet	newton-meters	1.356	metric tons	short tons	1.102
pound-inches	newton-meters	.11296			

Temperature (Exact)

°F	Fahrenheit temperature	5/9 (after subtracting 32)	Celsius temperature	°C
----	------------------------	----------------------------	---------------------	----

PIN: 061823-000